



**Government of India**  
**Ministry of Textiles**  
**Textiles Committee**



**Course Name: Wool Cleaning and Scouring Supervisor**  
**Course Code: TC WOOL 01**

**Version: 01**

**Developed by: Resource Support Agency (RSA), Textiles Committee, Ministry of  
Textiles, Government of India**

## **TABLE OF CONTENTS**

<b>1. Basic Textile Wet Processing Terms</b> .....	<b>01</b>
<b>2. Brief of all Wet Processing Stages</b> .....	<b>06</b>
2.1. Grey Fabric Inspection .....	<b>07</b>
2.2. Stitching .....	<b>07</b>
2.3. Brushing .....	<b>07</b>
2.4. Shearing/Cropping .....	<b>07</b>
2.5. Singeing .....	<b>07</b>
2.6. Desizing .....	<b>08</b>
2.7. Scouring .....	<b>08</b>
2.8. Bleaching .....	<b>09</b>
2.9. Mercerisation .....	<b>10</b>
2.10. Heat Setting .....	<b>10</b>
2.11. Dyeing .....	<b>11</b>
2.12. Printing .....	<b>12</b>
2.13. Finishing .....	<b>13</b>
2.14. Quality Assurance Laboratory .....	<b>14</b>
2.15. Effluent Treatment Plant .....	<b>14</b>
<b>3. Introduction to Wool</b> .....	<b>15</b>
3.1. What is Wool? .....	<b>15</b>
3.2. Types of Wool .....	<b>15</b>
<b>4. Composition of Wool</b> .....	<b>18</b>
5.1. Chemical Structure of Wool .....	<b>18</b>
5.2. Morphological Structure of Wool .....	<b>18</b>
<b>5. Properties of Wool</b> .....	<b>21</b>
6.1. Physical properties of wool .....	<b>21</b>
6.2. Chemical Properties of Wool .....	<b>22</b>
6.3. End-Use Properties of Wool .....	<b>23</b>
6.4. Uses & Application of Wool Fibre .....	<b>23</b>
<b>6. Wool Manufacturing Process</b> .....	<b>25</b>
Flow Chart of Wool Processing .....	<b>25</b>
6.1. Shearing .....	<b>26</b>

6.2. Grading and Sorting . . . . .	27
6.3. Cleaning and Scouring . . . . .	28
6.4. Carbonisation of Wool . . . . .	29
6.5. Bleaching of Wool . . . . .	29
6.6. Carding . . . . .	31
6.7. Drafting and Doubling . . . . .	31
6.8. Gilling . . . . .	32
6.9. Spinning . . . . .	34
6.10. Weaving . . . . .	35
6.11. Finishing . . . . .	35
<b>7. Cleaning and Scouring of Wool . . . . .</b>	<b>36</b>
7.1. Contaminants of Wool . . . . .	36
7.2. The Objectives of Wool Scouring . . . . .	37
7.3. Methods of Wool Scouring . . . . .	38
7.3.1. Freezing Process . . . . .	39
7.3.2. Solvent Scouring . . . . .	39
7.3.3. Detergent Scouring . . . . .	40
7.3.4. Bio-Scouring . . . . .	42
7.3.5. Scoring of Wool by Low Temperature Plasma Treatment. . .	42
<b>8. Wool Fibre Scouring . . . . .</b>	<b>43</b>
8.1. Wool Fibre Scouring Machines . . . . .	43
8.1.1. Swing Rake Machine . . . . .	43
8.1.2. Harrow Machine . . . . .	44
8.1.3. Paddle Machine . . . . .	46
8.2. Conventional Wool Scouring Machine . . . . .	47
8.3. Back Washing . . . . .	50
8.4. Drying of Wool . . . . .	51
<b>9. Wool Fibre Scouring Machine Operating . . . . .</b>	<b>52</b>
9.1. Scouring of Wool Fibres . . . . .	52
9.2. Drying of Wool Fibres . . . . .	59
9.3. Handling of Scoured Wool . . . . .	61
<b>10. Woollen Yarn Scouring . . . . .</b>	<b>64</b>
10.1. Tape Scouring Machine . . . . .	64
10.2. Brattice Scouring machine . . . . .	65

<b>11.</b>	<b>Wool Fabric Scouring</b> .....	<b>67</b>
	11.1. Wool Scouring on Winch .....	<b>67</b>
	11.2. Wool Scouring on Jet/Overflow Dyeing Machine .....	<b>68</b>
<b>12.</b>	<b>Scouring Waste Management s</b> .....	<b>70</b>
	12.1. Basics of Waste Minimisation .....	<b>70</b>
	12.2. Primary Treatments .....	<b>71</b>
	12.3. Other Treatments .....	<b>73</b>
<b>13.</b>	<b>Instructions During Shift Change Over</b> .....	<b>74</b>
<b>14.</b>	<b>Importance of Health and Safety</b> .....	<b>75</b>

# Chapter 1

## BASIC TEXTILE WET PROCESSING TERMS

**Absorbency:** The ability of one material to take up another material. In textiles, it is the ability of fibre/fabric to take the water quickly.

**Acidic:** A term describing a material having a pH of less than 7.0 in water

**Affinity:** Chemical attraction; the tendency of two elements or substances to unite or combine together, such as fibre and dyestuff. Affinity is usually expressed in units of joules (or calories) per mole.

**After-treatment:** Any treatment done after fabric production. In dyeing, it refers to treating dyed material in ways to improve properties; in nonwovens, it refers to finishing processes carried out after a web has been formed and bonded. Examples are embossing, creping, softening, printing and dyeing.

**Alkaline:** A term used to describe a material having a pH greater than 7.0 in water.

**Antichlor:** A chemical, such as sodium thiosulfate, used to remove excess chlorine after bleaching.

**Azoic dyes:** The dyes, produced by interaction of a diazotized amine (azoic diazo component) and a coupling component (azoic coupling component).

**Basic dyes:** A class of positive-ion-carrying dyes known for their brilliant hues. Basic dyes are composed of large-molecule that have a direct affinity for wool and silk and can be applied to cotton with a mordant. These are also known as a cationic dye.

**Auxiliaries:** Chemicals used to facilitate and modify the pre-treatment, dyeing, printing and finishing processes.

**Bleaching:** This is the process in which natural and added impurities in fabrics are removed to obtain clear whites.

**Bleeding:** Colour rinsing out of a finished garment, yarn, or fibre. Bleeding can be excess dye that was not fully rinsed out or dye that was not properly set on the fibre. Indigo is an exception, see crocking.

**Buffering Agent (Buffer):** A chemical additive that helps stabilize the dye bath pH.

**Carbonizing:** This is a chemical process for eliminating cellulosic material from, synthetic and wool or other animal fibres. The material is reacted with sulfuric acid or hydrogen chloride gas followed by heating. When the material is dry, the carbonized cellulose material is dust-like and can be removed.

**Carrier:** A product added to a dye-bath to promote the dyeing of hydrophobic fibres and characterized by affinity for, and ability to swell, the fibre.

**Caustic Soda:** The common name for sodium hydroxide (NaOH)

**Cheese:** A cylindrical package of yarn wound on a flangeless tube.

**Chrome dye:** A mordant dye capable of forming a chelate complex with a chromium ion.

**Colourant:** A colouring matter, a dye or pigment which can produce colour in a substrate like fibre, yarn or fabric.

**Colouration:** A series of textile operation involved to impart colour in textiles. It embraces dyeing, printing, painting, spraying and preparatory treatment as well.

**Colourfastness:** Resistance to fading; i.e. the property of a dye to retain its colour when the dyed (or printed) textile material is exposed to conditions or agents such as light, perspiration, atmospheric gases, or washing that can remove or destroy the colour.

**Colour strength:** A measure of the ability of a dye to impart colour to other materials. Colour strength is evaluated by light absorption in the visible region of the spectrum.

**Compatibility:** In textile dyeing, propensity of individual dye components in a combination shade to exhaust at similar rates resulting in a build up of shade that is constant, or nearly constant, in hue throughout the dyeing process.

**Cross dyeing:** A process of dyeing textiles containing fibres having different dye affinities to achieve a multicoloured effect.

**Depth of Shade:** a percentage describing the amount of dye used proportional to the dry fibre weight, or OWOG. To dye 100 grams of fibre to a 1% DOS, your dye powder would weigh 1% of 100 grams, or 1 gram.

**Detergent:** A detergent is a compound or a mixture of compounds, intended to assist cleaning & acts mainly on the oily films that trap dirt particles.

**Direct dyes:** A class of dyestuffs that are applied directly to the substrate in a neutral or slightly alkaline bath. They produce full shades on cotton and linen without mordanting and can also be applied to rayon, silk and wool. Direct dyes give bright shades but exhibit poor wash fastness.

**Disperse dyes:** A class of water-insoluble or slightly soluble dyes originally introduced for dyeing cellulose acetate and usually applied from fine aqueous suspensions. Disperse dyes are widely used for dyeing most of the manufactured fibres.

**Dyes/dyestuff:** Substances that add colour to textiles. They are incorporated into the fibre by chemical reaction, absorption, or dispersion. Dyes may be divided into natural and synthetic types.

**Dye liquor:** The liquid that contains the dye and other chemicals or auxiliaries necessary for dyeing.

**Effluent:** Waste water released after pretreatment, dyeing & finishing of Textile.

**Exhaustion:** During wet processing, the ratio at any time between the amount of dye or substance taken up by the substrate and the amount originally available.

**Fast or Fastness:** A fast colour will not fade due to exposure to light or washing.

**Fixation:** The process of setting a dye after dyeing or printing, usually by steaming or other heat treatment.

**Florescent whitening agent (FWA):** Colourant that absorbs near ultraviolet (UV) radiation and re-emits visible (violet-blue) radiation. This causes a yellowish material to which it has been applied to appear whiter.

**Hard water:** Water described as "hard" is high in dissolved minerals, specifically calcium and magnesium. Hard water is not a health risk, but a nuisance because of mineral buildup on fixtures and poor soap and/or detergent performance.

**Heat setting:** Heat-setting is a heat treatment by which shape retention, crease resistance, resilience and elasticity are imparted to the fibres. It also brings changes in strength, stretchability, softness, dyeability and sometimes on the colour of the material.

**Hydrophilic:** Having strong affinity for or the ability to absorb water.

**Hydrophobic:** Lacking affinity for or the ability to absorb water.

**Inhibitor:** A substance that retards or prevents a chemical or physical change. In textiles, it is a chemical agent that is added to prevent fading, degradation, or other undesirable effects.

**Jet dyeing machine:** A high-temperature piece dyeing machine that circulates the dye liquor through a Venturi jet, thus imparting a driving force to move the fabric. The fabric, in rope form, is sewn together to form a loop.

**Kier boiling:** Process of boiling cellulosic materials in alkaline liquors in a kier at or above atmospheric pressure.

**Liquor ratio:** In wet processing the ratio of the weight of liquid used to the weight of goods treated.

**Metal-complex dye:** A dye having a coordinated metal atom in its molecule. Unless the term metal-complex dye is used in direct association with a particular application

class of dye, e.g. metal-complex disperse dye or metal-complex reactive dye, its use is inexact and inadvisable.

**Migration:** Movement of an added substance (e.g. dye or alkali) from one area to textiles to another. The term commonly used to express the movement of colour from the dyed area to the undyed area of cloth.

**Mordant:** A chemical used in some textile fibres to provide affinity for dyes. Or a substance, usually a metallic compound, applied to a substrate to form with a dye a complex which is retained by the substrate more firmly than the dye itself.

**Mordant dye:** A dye that is fixed with a suitable mordant.

**Natural Dyes:** Dyes made from natural substances, usually from the bark, leaves, roots, flowers, or wood of a plant. There are also insects, notably cochineal and lac, that make dyes.

**Pad:** A machine for impregnating fabrics with chemicals. It consists essentially of a trough followed by two or more pairs of squeeze rolls.

**pH:** Value indicating the acidity or alkalinity of a material. It is the negative logarithm of the effective hydrogen ion concentration. A pH of 7.0 is neutral; less than 7.0 is acidic; and more than 7.0 is basic.

**Reactive dye:** A dye that, under suitable conditions, is capable of reacting chemically with a substrate to form a covalent dye-substrate linkage.

**Reduction clearing (RC):** The removals of unabsorbed disperse dye from the surface of polyester at the end of the dyeing or printing process by treatment in a sodium hydroxide/sodium hydrosulfite bath. A surface-active agent may be employed in the process.

**Retarder (Retardants):** A chemical that, when added to the dye bath, decreases the rate of dyeing but does not affect the final exhaustion.

**Scouring:** In textile processing, treatment of textile materials in aqueous or other solutions to remove nature fats, waxes, proteins and other constituents as well as dirt, oil and other impurities.

**Shade:** A common term loosely used to describe broadly a particular colour or depth, e.g. pale shade, 2% shade, mode shade, fashion shade.

**Solvent dye:** A dye which is soluble in organic solvents, but not in water, and is widely used in lacquers, inks, waxes, plastics, soaps, cosmetics, fuels and coloured smokes.

**Souring:** The term refers to the treatment of textile materials in dilute acid. Its purpose is the neutralization of any alkali that is present.



**Sulfur dye:** A dye, containing sulfur both as an integral part of the chromophore and in attached polysulfide chains, normally applied in the alkali-soluble reduced (leuco) form from a sodium sulfide solution and subsequently oxidized to the insoluble form in the fibre.

**Surfactant:** An agent, soluble or dispersible in a liquid, which decreases the surface tension of the liquid. It is also called as a “surface active agent”

**Vat dyes:** A water-insoluble dye, usually containing keto groups, which is normally, applied from an alkaline aqueous solution of the reduced enol (Leuco) form which is subsequently oxidized in the fibre to the insoluble (parent) dye form.

**Wash fastness:** A measure of resistance to fading by laundering. Wash fastness of different dyes are measured at different conditions, like temperature, time, detergent, etc.

**Wetting agent:** It is a chemical substance that increases the spreading & penetrating properties of a liquid by lowering its surface tension that is the tendency of its molecules to adhere to each other.

**Wet pick-up:** The weight of liquor taken up by a given weight of the fabric after impregnation, spraying, or coating element.

## Chapter 2

### **BRIEF OF ALL WET PROCESSING STAGES**

#### **2.1. Sequence of operations in wet processing**

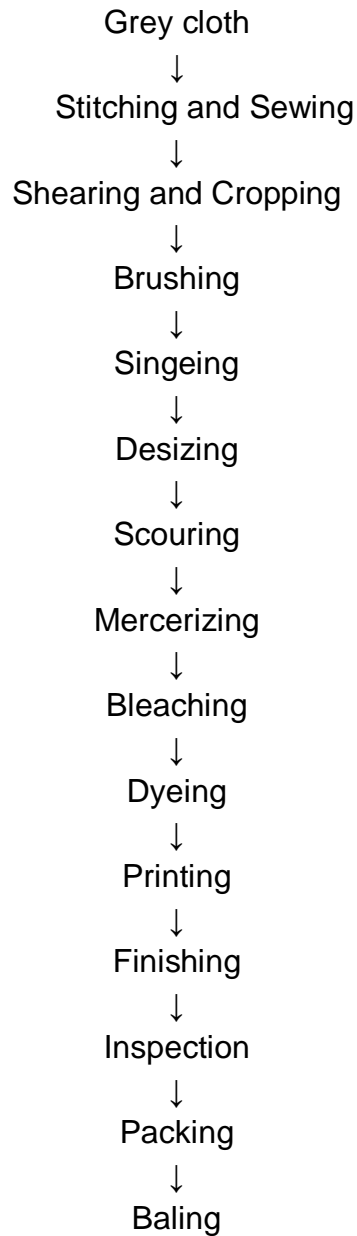

### **2.1.1. Grey Fabric Inspection**

After manufacturing fabric it is inspected on an inspection table. It is the process to remove neps, warp end breakage, weft end breakage, holes, spots, etc.

### **2.1.2. Stitching**

Stitching is done to increase the length of the fabric for making suitable for processing. It is done by plain sewing m/c.

### **2.1.3. Brushing**

To remove the dirt, dust, loose fibre & loose ends of the warp & weft threads is known as brushing.

### **2.1.4. Shearing/Cropping**

The process by which the attached ends of the warp & weft thread are removed by cutting by the knives or blades is called shearing. Shearing is done for cotton & cropping for jute.

### **2.1.5. Singeing**

The process by which the protruding / projecting fibres are removed from the fabrics by burning / heat to increase the smoothness of the fabric is called singeing. If required both sides of fabric are singed.

#### **2.1.5.1. Advantages of Singeing**

- ✓ Improved end use and wearing properties
- ✓ Clean Surface.
- ✓ Reduced fogginess.
- ✓ Reduced pilling.
- ✓ Reduced Soiling

Singeing usually involves passing/exposing one or both sides of a fabric over a gas flame to burn off the protruding fibres. The temperature of the flame is quite high, hence the fabric is passed over the flame at a high speed such that loose protruding fibres are burnt off but the fabric itself remains undamaged. Heat or the temperature is therefore a key parameter in singeing.

Other methods of singeing include infra-red singeing and heat singeing for thermoplastic fibres. Thermoplastic fibres are harder to singe because they melt and form hard residues on the fabric surface

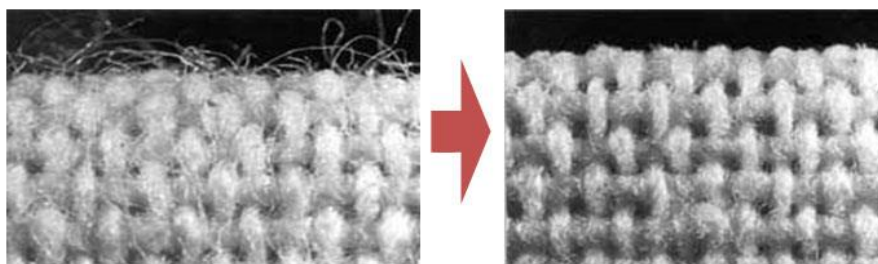

Un-singed Fabric

Singed Fabric

### 2.1.6. Desizing

Desizing is the process of removal of size material applied on warp threads of a fabric to facilitate the process of weaving. Size forms a stiff, hard and smooth coating on warp yarns to enable them to withstand the cyclic tensions during weaving and reduce breakage

There are three types of Desizing methods namely, Rot steeping, Acid desizing and enzymatic desizing. Enzymatic desizing is more popular and mostly practiced desizing method because it is very safe and does not cause any damage to the fabric. This is one of the important textile pre-treatment processes to get trouble free dyeing.

### 2.1.7. Scouring

Scouring is the next process after desizing in which the water insoluble impurities, such as the natural fats and waxes as well as added impurities present in the fabric are removed. Due to the removal of these impurities the absorbency of the fabric increases to the greater extent, which results in efficient further processing.

There are two ways to carry out scouring: 1. Alkali Scouring. 2. Solvent Scouring. Normally, alkali scouring is carried out and the alkali used is sodium hydroxide.

#### 2.1.7.1. Objects of Scouring

- To remove natural fat, wax and oil materials containing in the fabrics without damaging the fibres.
- To accelerate dye and chemical absorption of the fabrics.
- To improve the handle of the goods.
- To remove non-cellulosic substance in case of cotton.

### 2.1.7.2. Reactions Occur During Scouring

- Saponification of oils and fatty acids converted into soaps
- Pectin are converted into sodium salts of pectic acids.
- Proteins are hydrolysed into soluble products
- Mineral matters are dissolved into water
- Unsaponifiable oils and waxes are emulsified.
- Dust particles are removed and held in suspensions.

### 2.1.7.3 Scouring Processes

Scouring is carried out by three methods

- i. Batch scouring – Scouring on jigger, kier boiling, winch machine
- ii. Semi-continuous scouring - Pad-batch, pad-steam process, J-box.
- iii. Continuous Scouring – Pad-steam process

General recipe for scouring process:

Alkali (NaOH)	2 - 5 gm/l
Soda ash	2 - 5 gm/l
Wetting agent	1 gm/l
Sequestering agent	1 gm/l
Detergent	1 - 2 gm/l

Recently new method of scouring is invented, i.e. Bio-scouring. Bio-scouring with pectinase enzymes have shown poise in replacing the traditional scouring treatment.

### 2.1.8. Bleaching

The scouring process of cotton removes waxes and other majority of impurities leaving behind the natural colouring matter. Bleaching completes the purification of fibre by ensuring the complete decolourisation of colouring matter.

Bleaching can be done by oxidative or reductive bleaching agent. The important Oxidative bleaching agents are hydrogen peroxide, sodium or calcium hypochlorite and sodium chlorite. The main reducing agents are Sodium hydrosulphite, sulphonylates, sodium bisulphites and thioureadioxide increases.

The bleaching process must ensure:

- ✓ A pure and permanent whiteness.
- ✓ Level dyeing properties (There should be no variation in bleaching).

- ✓ Three should not be any loss in tensile strength due to degradation of cellulose.
- ✓ Eco-Friendly bleaching should be preferred.
- ✓ Hydrogen Peroxide is the most widely used bleaching agent.

Bleaching may be carried out using enzymatic bleaching agents. The most popular and preferred bleaching agent is hydrogen peroxide. Hydrogen peroxide bleaching can be done by

- i. Batch wise
- ii. Semi-continuous
- iii. Continuous

Batch wise bleaching can be carried out using jigger, winch or kier. In semi-continuous bleaching, initially the fabric is padded through bleaching agent & required chemicals and batched. Then the batching rolls steamed followed by washing and neutralising. In case of continuous bleaching; padding, steaming and washing operation is in continuous form.

#### **2.1.9. Mercerizing**

In this process, the cellulosic materials/substance is treated with high concentration of sodium hydroxide (NaOH) for short time and then washed. The main objectives of mercerisation are;

- ✓ To Improve dimensional stability
- ✓ To Increased dye uptake
- ✓ To Improve strength
- ✓ To Improve moisture regain
- ✓ To improve lustre

#### **2.1.10. Heat Setting**

The purpose of heat setting is to dimensionally stabilize fabrics containing thermoplastic fibres. Polyester and nylon are the principal fibres involved. Blended polyester/cotton fabrics are produced in large quantities. These fabrics may shrink, or otherwise become distorted either during wet processing or in the consumer's hands. Heat setting is a way of reducing or eliminating these undesirable properties.

The process is relatively simple - pass the fabric through a heating zone for a time and at a temperature that resets the thermoplastic fibre's morphology memory. The new memory relieves the stresses and strains imparted to the fibre by the yarn making and weaving processes, and makes stable the configuration it finds itself in flat smooth fabric. This newly imparted memory allows the fibre to resist fabric distorting forces and provides a way to recover from them. The time and temperature needed for the heat treatment depend on fabric density and previous heat history of the polyester. Time and temperature must exceed that imparted by previous heat treatments. Usually 15 - 90 seconds at temperatures of 180 – 200°C will suffice. The heat setting equipment can be hot air in a stenter frame, or surface contact heat from hot cans. While the process is simple, careful control is required.

### **2.1.11. Dyeing**

Dyeing is the process of colouring fibres, yarns, or fabrics with either natural or synthetic dyes. Textiles are dyed using a wide range of dyestuffs, techniques, and equipment. Dyes used by the textile industry are largely synthetic, typically derived from coal tar and petroleum-based intermediates. Dyes are sold as powders, granules, pastes, and liquid dispersions.

Textiles can be coloured at any of several stages of the manufacturing process so that the following colouring processes are possible:

- stock dyeing
- top dyeing: fibres are shaped in lightly twisted roving before dyeing
- tow dyeing: it consists in dyeing the mono-filament material (called tow) produced during the manufacture of synthetic fibres
- yarn dyeing
- piece (e.g. woven, knitted and tufted cloths) dyeing
- ready-made goods (finished garments, carpet rugs, bathroom-sets, etc.).

Dyes can be used on vegetable, animal or man-made fibres only if they have affinity to them. Textile dyes include acid dyes, used mainly for dyeing wool, silk and nylon and direct or substantive dyes, which have a strong affinity for cellulose fibres.

Mordant dyes require the addition of chemical substances, such as salts to give them an affinity for the material being dyed. They are applied to cellulose fibres, wool or silk after such materials have been treated with metal salts.

#### **2.1.11.1. Methods of Dyeing**

Similar to scouring and bleaching, dyeing of fabric is carried out by three methods namely;

- i. Batch dyeing: jigger, winch, jet, etc.
- ii. Semi-continuous: pad batch, pad- roll -steam
- iii. Continuous: pad-steam

#### **2.1.12. Printing**

Printing can be defined as the localized application of dye or pigment in a thickened form to a substrate to generate a pattern or design. In the process of printing colour designs are developed on fabrics by printing with dyes and pigments in paste form with specially designed machines. Printing is used to apply colour only on localized areas.

There are three styles of Printing:

- a) Direct printing (which also includes digital and transfer printing)
- b) Discharge printing
- c) Resist printing.

**Direct style of printing:** In this type of printing dye is applied onto the fabric by carved block, stencil, screen, engraved roller, etc. The colour is applied to specific areas of a pre-treated textile substrate, which can be white or pre-dyed.

**Discharge style of printing:** In this method the fabric is dyed and then printed with a chemical that will destroy the colour in designed areas. Some time the base colour is removed and another colour printed in its place.

**Resist Style of printing:** In this method bleached fabric is printed with a paste containing resisting agent, dried and the fabric is dyed. Special dyeing technique is used in order to avoid the spoiling of resist printed area.



### 2.1.13. Finishing

Textile Finishing covers an extremely wide range of activities which are performed on textiles before they reach the final customer. The term finishing includes all the mechanical and chemical processes employed commercially to improve the acceptability of the product. Finishing processes might modify a fabric's final appearance, make it softer, or improve elements of its performance. Whichever process is done, textile finishing makes fabric more appealing to the consumer.

Objectives of Finishing

- i. To improve appearance of the fabrics
- ii. To meet up specific requirements of the fabrics to achieve the final goal.
- iii. To increase the life time of durability of the fabric

### 3.12.1. Classification of Textile Finishes

Textile finishes are classified in different ways

**Aesthetic finishes:** This type of finishes make change or modify the appearance of the fabric or hand/drape properties of the fabrics.

**Functional finishes:** This type of finishes changes the internal performance properties of the fabrics.

Finishes also classifies as follows.

***Mechanical finishes:*** This type of finishes also called as dry finishes. This type of finishes also involves specific physical treatment to the fabric surface to cause a change in fabric appearance. Mechanical finishing is considered a dry operation even though moisture and chemicals are often needed to successfully process the fabric. Calendaring, Sanding, Napping, Shearing, Decatising, Sanforizing (pre-shrinking) are the examples of mechanical finishes.

***Chemical finishes:*** This type of finishes usually applied to the fabric by padding followed by curing or drying. Chemical finishing or 'wet finishing' involves the addition of chemicals to textiles to achieve a desired result. In chemical finishing, water is used as the medium for applying the chemicals. Heat is used to drive off the water and to activate the chemicals. Softening, Stiffening, Wash-n-wear/durable press/anti-crease/wrinkle free finishes, Soil release finish, Water repellency, Flame retardancy, Antistatic finishes, Anti-pilling finishes and Anti-microbial finishes are examples of the chemical finishes.

### **2.1.14. Quality Assurance Laboratory**

The textile industry has a grave concern for maintaining high quality standards so it establishes rigid systems of inspection before the fabric gets finally packed. It is extremely essential to maintain a reputation of supplying fault free goods. Hence, the fabric undergoes test for product quality at every major stage of processing. The textile material is tested in an equipped laboratory and skilled technicians to maintain product quality. The fabric is instantly rejected if it is not within the specification limits. Modern quality control has been assisted by development of techniques and machines for assessing fabric properties. The automatic testing devices has greatly reduced testing time and cost.

### **2.1.15. Effluent Treatment Plant**

The textile industry generates a lot of toxic effluent during the processing of the fabric which has to be treated before its disposal the strict norms issued by the pollution control boards of respective states to the textile processing industry has helped to curb pollution and combat the menace quite effectively. The effluent process is divided into following process. 1. Physical. 2. Chemical. 3. Biological. 4. Tertiary.

## Chapter 3

### INTRODUCTION TO WOOL

#### 3.1. What is Wool?

Wool is one of the animal fibres obtained from sheep and some other animals. Animal fibres are the fibres that are naturally obtained from animals. Some animals that live in cold places generally have a thick coat of hair on their body. These coating helps the animals to trap air in it and keep them warm as air is a poor conductor of heat. Air trapped by the hair on the body of animals does not let the warmth to escape from the body. Hence, these thick covering of hair on animal body protect them from cold. Some of the animals are goat, camel, sheep etc.

Wool fibre is the natural hair grown on sheep and is composed of protein substance called as keratin. Wool is composed of carbon, hydrogen, nitrogen and this is the only animal fibre, which contains sulfur in addition. The wool fibres have crimps or curls, which create pockets and give the wool a spongy feel and create insulation for the wearer. The outside surface of the fibre consists of a series of serrated scales, which overlap each other much like the scales of a fish. Wool is the only fibre with such serration's which make it possible for the fibres to cling together and produce felt

#### 3.2. Types of Wool

There are two major kinds of cloth made from wool fibres: worsteds and woollens. Worsted wools have a smooth surface, feel firm to the touch, and have a minimum of fuzziness and nap. They are made from the longer wool fibres, usually 2 to 8 inches (5 to 20 cm), and require a more complicated manufacturing process than do woollens. Gabardines and crepes are examples of worsted fabrics. Woollens have a random arrangement of fibres that gives them more bulk and a soft, fuzzy surface. Fabrics made of woollen yarn include homespun, tweed, flannel wool, and Shetland wool. There are two major classifications of raw wool, based on its final use: apparel wool and carpet wool. Carpet wool is coarser and usually longer than apparel wool.

The finest wool comes from Merino sheep. The fleece of these sheep is also called merino. The fibres of merino wool are so fine that a string of them a mile long would weigh only 0.01 ounce (0.30 gram). Merino wools come from Australia, South Africa, and South America. The best merino wools come from Australia, where the sheep receive better care. Merino wool has shorter fibres than does the wool from English sheep; the longest wool fibres are from Lincolnshire and Leicestershire. The coarse carpet or braid wools come from Turkey and Argentina.

Crossbred sheep, developed by crossing Merino sheep with other types, produce wool in England, New Zealand, and South America. The United States wool also comes from crossbred sheep such as Corriedale, Southdown, Shropshire, Dorset, and Hampshire. The classification of wool in the United States is based on the section of the country from which the wool comes. Domestic wools come from the Eastern and Midwestern states, territory wools from the Rocky Mountain plateau states, and south-western wools from Texas, New Mexico, Arizona, and southern California.



**Merino:** Merino sheep, known for having softer coats than others, are the source of this soft and popular wool. It draws moisture away from the skin on one end of the fibre and repels outside moisture on the fibre.



**Alpaca:** Supplied by the alpaca, this fine silk fabric is warmer than sheep wool. Look for it in sweaters, coats, gloves, scarves and soeties in upholstery.



**Mohair:** This lustrous fibre is made from the hair of the Angora goat. Like merino, mohair fibres are moisture-wicking and good insulators, but they have more sheen which makes fabric made from them more attractive. It's also wears better than sheep's wool.



**Llama:** The llama produces a fibre which is naturally glistening. Although they're related to llamas, llamas have fibres that are coarser and weaker. But they give good warmth without being too heavy.



**Angora:** Made from the hair of the Angora rabbit, this heat-retaining fibre is ideal for thermal clothing. As it's lightweight as well as soft, it's very comfortable to wear.



**Cashmere:** Like mohair, cashmere comes from the hair of goat, the Kashmir goat. Soft to the touch so it's a pleasure to wear, it's also extremely adept at keeping you warm. Cashmere is the most common type of fine wool used in clothing.



**Cashgora:** This hybrid wool comes from a crossbreed of a Cashmere buck and an Angora doe. You'll find it finer than mohair but less so than cashmere.

## Chapter 4

### COMPOSITION OF WOOL

Wool fibres are extremely complex, highly cross linked keratin proteins made up of 17 different amino acids. The amino acid content and sequence in wool varies with variety of wool. The wool protein chains are joined periodically through the disulphide cross linked cystine, an amino acid that is contained within two adjacent chains. The cross linked protein structure packs and associates to form fibrils, which in turn make up the spindle shaped cortical cells which constitute the cortex or interior of the fibre. The cortex is surrounded by an outer sheath of scale like layer or cuticle, which accounts for the scaled appearance running along the surface of the fibre (shown in figure below).

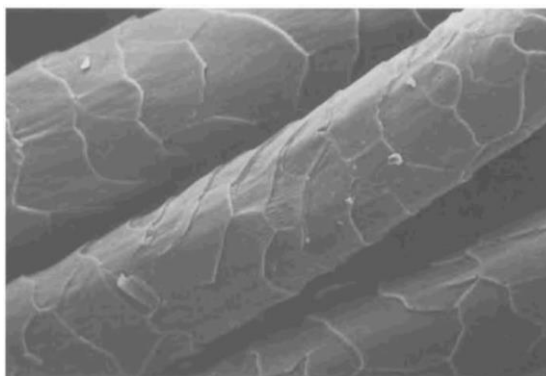

*Figure: Electron micrograph of wool fibre*

#### 4.1. Chemical Structure of Wool

Wool is a member of a group of proteins known as keratins. A characteristic feature of hard keratins, such as wool, hair, hooves, horns, claws, beaks and feathers, is a higher concentration of sulphur (in excess of 3%) than is found in soft keratins such as those in skin. The sulphur is present mainly in the form of residues of the amino acid cystine. Wool is composed of 18 amino acids.

Keratin fibres consist of a complex mixture of widely different polypeptides. It has been estimated that wool contains about 170 different types of protein molecule.

#### 4.2. Morphological structure of Wool

The complex morphological structure of fine wool fibres is shown schematically below Figure. Fine wools contain two types of cell: the cells of the

external cuticle and those of the internal cortex. Together, these constitute the major part of the mass of clean wool.

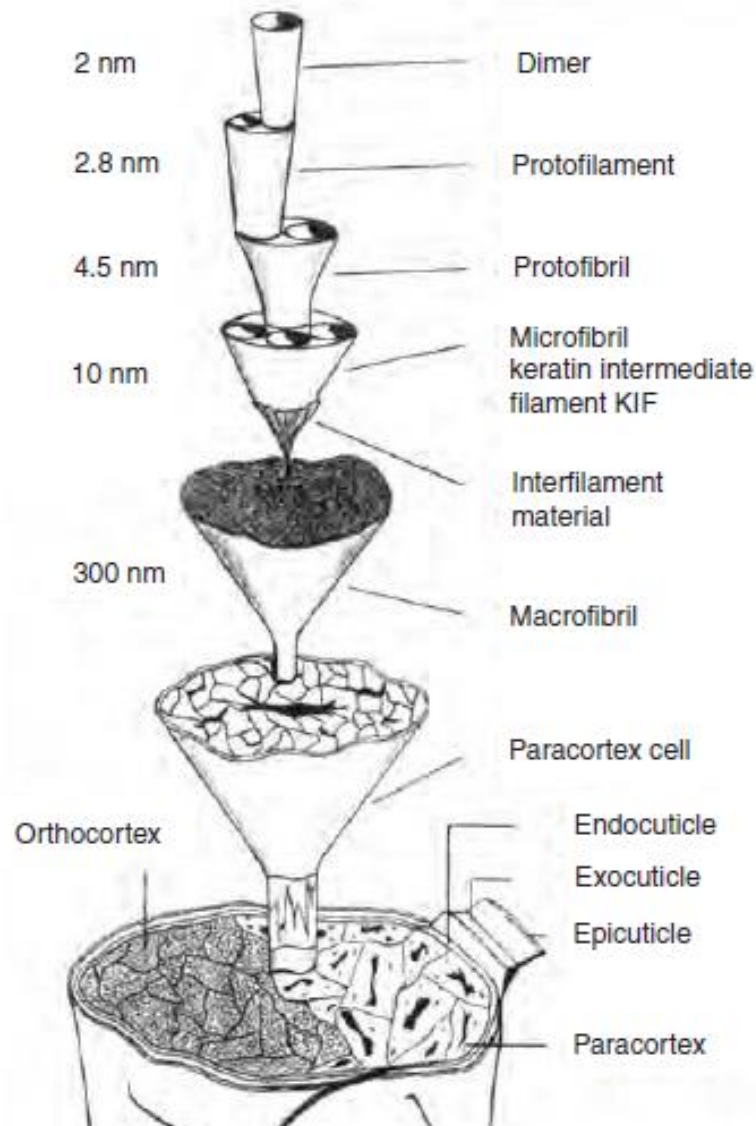

**Figure: Morphological structure of fine wool fibres**

**Cuticle:** The cuticle is the layer of overlapping epithelial cells surrounding the wool fibre. There are three cuticles;

- i. Epi Cuticle: The epicuticle is the outermost layer covers of the wool fibre.
- ii. Exo Cuticle: The overlapping epithelial cell forms the exocuticle.
- iii. Endocuticle: The endocuticle is the intermediate connecting layer bonding the epithelial cell of the cortex of wool fibre.

The cuticle cells, or scales, constitute the outermost surface of the wool fibre and are responsible for important properties such as wettability, tactile properties

and felting behaviour. Approximately 10% of a fine wool fibre consists of cuticle cells. The amount of each cuticle cell visible on the wool surface varies with fibre diameter; for fine wools the amount of scale overlap is approximately 15%.

**Cortex:** The cortex – the internal cells-make up 90% of the fibre. There are two main types of cortical cells i.e. ortho-cortical and para-cortical. In finer fibres, these two types of cells form in two distinct halves. The cells expand differently when they absorb moisture, making the fibre bend-this creates the crimp in wool. In coarser fibres, the para-cortical and ortho-cortical cells form more randomly so there's less crimp. Fibre crimp makes wool feel springy and provides insulation by trapping air.

The cortex, comprising 90% of the fibre, consists of different kinds of cortex cells, ortho- (60–90%) and paracortex cells (40–10%), the latter containing a larger amount of sulphur than the former and hence being tougher and more highly cross-linked. Each cortical cell is composed of 5–20 macrofibrils at the widest point with a diameter of 100–300 nm. The macrofibrils are composed of bundles of 500–800 microfibrils.

**Cortical cell:** The cortical cells are surrounded and held together by a cell membrane complex, acting similarly to mortar holding bricks together in a wall. The cell membrane complex contains proteins and waxy lipids and runs through the whole fibre and allows easy uptake of dye molecules. The molecules in this region have fairly weak intermolecular bonds, which can break down when exposed to continued abrasion and strong chemicals.

**Macro-fibril:** Inside the cortical cells, there are long filaments called macro-fibrils. These are made up of bundles of even finer filaments called microfibrils, which are surrounded by a matrix region.

**Matrix:** The matrix consists of high sulphur proteins. This makes wool absorbent because sulphur atoms attract water molecules. Wool can absorb up to 30% of its weight in water and can also absorb and retain large amounts of dye. This region is also responsible for wool's fire-resistance and anti-static properties.

**Micro-fibril:** Within the matrix area, there are embedded smaller units called microfibrils. The microfibrils in the matrix are rather like the steel rods embedded in reinforced concrete to give strength and flexibility. The microfibrils contain pairs of twisted molecular chains.



## Chapter 5

### PROPERTIES OF WOOL

#### 5.1. Physical Properties of Wool

At 2% extension, wool shows 99% recovery, and even at 20% extension a recovery as high as 65% is observed. Wool fibres have excellent resiliency and recover readily from deformation except under high humidities. The stiffness of wool varies according to the source and the diameter of the individual fibres. Wool is little affected by heat up to 150°C and is a good heat insulator due to its low heat conductivity and bulkiness, which permits air entrapment in wool textile structure.

**Colour:** The colour of wool fibre could be white, near white, brown and black

**Tensile Strength:** The tensile strength of wool in dry condition is 1 – 1.7 and 0.8 - 1.6 in wet condition.

**Elongation at break:** Standard elongation is 25 – 35 % and 25 -50 % in wet condition.

**Elastic recovery:** Good

**Specific Gravity:** Specific gravity is 1.3 – 1.32.

**Moisture Regain:** 16- - 18%

**Resiliency:** Excellent

**Lustre:** Lustre of coarse fibre is higher than fine fibre.

**Effect of Heat:** Heat affects wool fibre greatly. Wool becomes weak for heat. It softens when heated or treated with boiling water for long time. At 130°C it decomposes and chars at 300°C. Wool does not continue to burn when it is removed from a flame.

**Effect of Sunlight:** Wool will weaken when exposed to sunlight for long periods. The ultraviolet rays will cause the disulfide bonds of cystine to break, which leads to photochemical oxidation. Wool is attacked by short wavelength (300 – 450 nm) UV light, causing slow degradation and yellowing. The main chemical component (Keratin) of wool decomposes under the action of sunlight.

## 5.2. Chemical Properties of Wool

Wool is resistant to attack by acids but is extremely vulnerable to attack by weak bases even at low dilutions. Wool is irreversibly damaged and coloured by dilute oxidizing bleaches such as hypochlorite. Reducing agents cause reductive scission of disulfide bonds within the wool. Wool is attacked by short wavelength (300-350 nm) ultraviolet light, causing slow degradation and yellowing. On heating, wool degrades and yellowing above 150°C and chars at 300°C.

**Effect of Acids:** Wool is more resistant to acids. Wool is attacked by hot concentrated sulphuric acid and decomposes completely. It is in general resistant to mineral acids of all strengths even at high temperature though nitric acid tends to cause damage by oxidation. Dilute acids are used for removing cotton from mixtures of two fibres; Sulphuric acid is used to remove vegetable matter in the carbonizing process. Wool is only damaged by hot sulphuric acid and nitric acid.

**Effect of Alkalis:** The chemical nature of wool keratin is such that it is particularly sensitive to alkaline substances. Strong alkaline affects wool fibre, but weak alkaline does not affect wool. Wool dissolves when boiled in a 5% solution of sodium hydroxide. Weak solutions of sodium carbonates can damage wool when used hot, or for a long period.

**Effect of Organic Solvent:** Wool does not affect in organic solvents

**Effect of Insects:** Wool affected by insects.

**Effects of Micro Organisms:** Wool is affected by mildew if it remains wet for longer time.

**Effect of Bleaches:** Bleaches that contain chlorine compounds will damage wool. Products with hypochlorite will cause wool to become yellow and dissolve it at room temperature. Various forms of chlorine are used to make 'unshrinkable wool', by destroying the scales. This wool is weaker, less elastic and has no feeling properties. Wool is irreversibly damaged and colored by dilute oxidizing bleaches such as hypochlorite.

**Reduction:** Under controlled conditions, reducing agents can be used to partially reduce the wool.

**Effect of perspiration:** As already stated, wool is easily deteriorated by alkalis and therefore perspiration which is alkaline will weaken wool as a result of hydrolysis of peptide bonds and amide side chains. Perspiration in general will lead to discoloration.

**Dyeing ability:** Wool fibre could be dyed by Basic dye, Direct dye and Acid dye. All the wool fibres are not same in characteristics. It varies depending on the wool's country of origin and sheep type.

### 5.3. End-Use Properties of Wool

Wool varieties including merino, Lincoln, Leicester, Sussex, Cheviot, Raboulett and Shetland, as well as many others. wool is a fibre of high to moderate luster. Wool fabric possesses a soft to moderate hand and exhibits good drapability. Wool fibres are highly absorbent and have excellent moisture transmission properties.

The low to moderate strength of wool fibres is compensated for by its good stretch and recovery properties. Wool is fairly abrasion resistant and does not tend to form pills due to its low strength. It resists wrinkling except under warm, moist conditions. Its crease retention is poor unless creases have been set using chemical reducing agents.

Due to its affinity for water, wool is slow drying. Wool may be ironed at 150°C or below without steaming. Wool is self-extinguishing fibre and burns very slowly even in contact with a flame. It has a Limiting Oxygen Index (LOI) of 25.

Wool is extensively used in textile applications, where comfort and aesthetics are important. It is used in men's and women's apparel, outer wear and cold weather clothing, suits, blankets, felts, and carpeting. It is often used in blends with cellulosic and man-made fibres.

### 5.4. Uses & Application of Wool Fibre

Wool is extensively used in textile applications where comfort and aesthetics are important. Some uses and application of wool fibre are given below –

- ✓ Wool fibre used for clothing, blankets, insulation and upholstery.
- ✓ It is used in men's and women's apparel, outer wear and cold weather clothing, suits, blankets, felts and carpeting.

- ✓ It is often used in blends with cellulosic and man-made fibres.
- ✓ It is also used for absorb noise of heavy machinery and stereo speakers.
- ✓ As an animal protein wool, can be used as a soil fertilizers, being a slow release source of nitrogen.

#### **5.4.1. End Uses of Wool Fibres**

**Alpaca** fibres are used for many purposes, including making clothing such as hats, mitts, scarves, gloves. And jumpers. Rugs and toys can also be made from alpaca fibres. Alpaca fleeces is generally used only in the expensive luxury items of textile and apparel

**Lama** fibres are used in expensive knitted fabrics, jackets, over – coats, and blankets.

**Camel hair** is used for outer wear and used for under linings

**Cashmere** is used in luxury applications where a soft, warm, fine fibre with beautiful drape is desired.

**Mohair** is used for outer – wear.

## Chapter 6

### WOOL MANUFACTURING PROCESS

In the beginning of the manufacturing process, woollen and worsted fleece are handled in the same way. Subsequently, worsted yarns generally undergo more processing stages than woollen yarns.

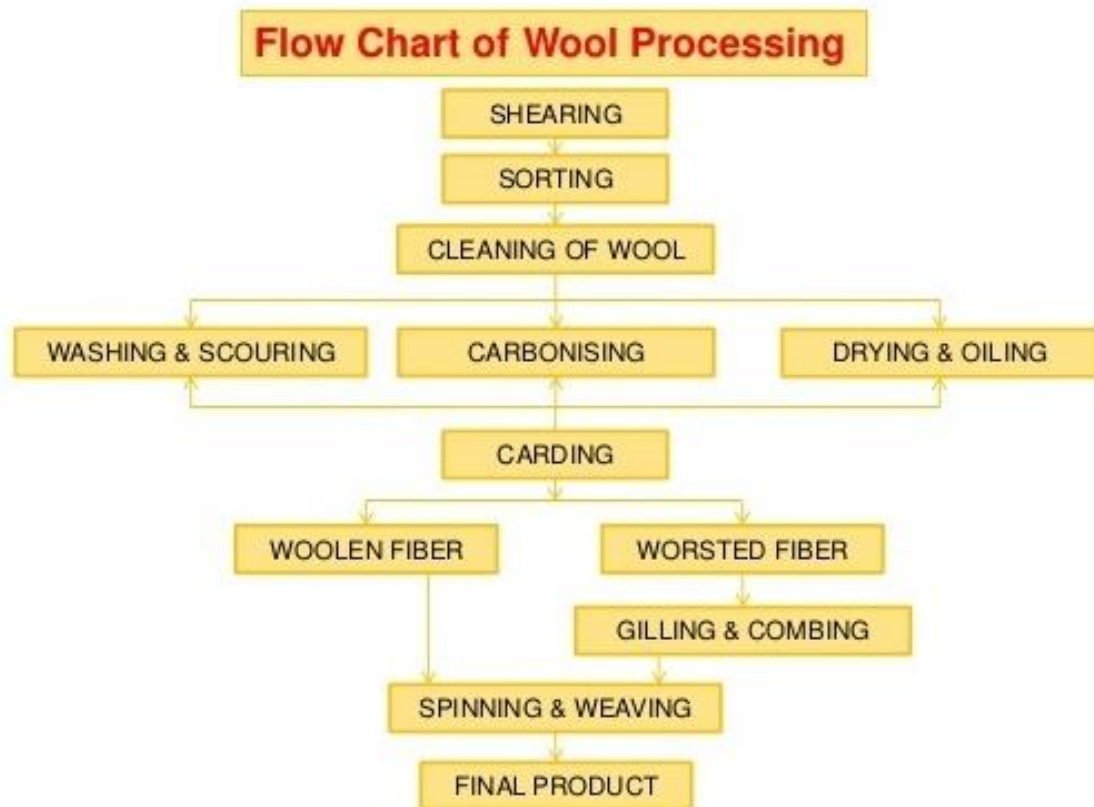

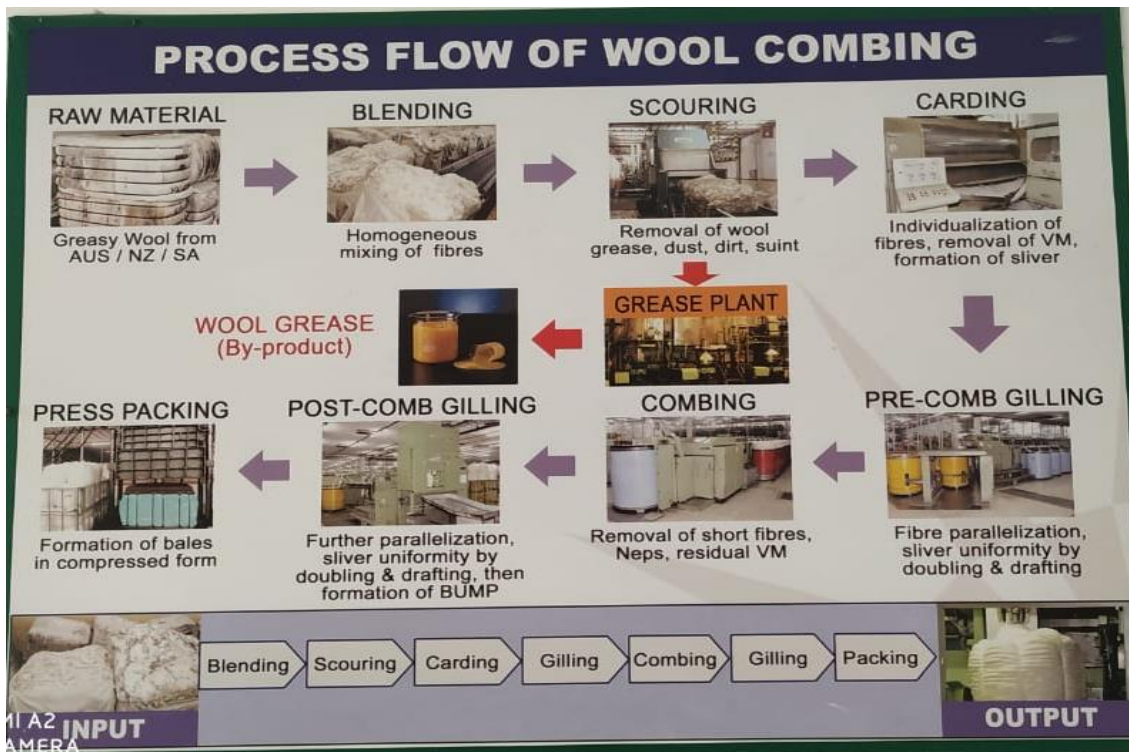

The major steps necessary to process wool from the sheep to the fabric are:

- Shearing
- Grading and sorting
- Cleaning and scouring
- Carbonization of Wool
- Bleaching of Wool
- Carding
- Drafting and doubling
- Combing
- Spinning
- Weaving
- Finishing.

### 6.1. Shearing

Sheep are sheared once a year—usually in the springtime. A veteran shearer can shear up to two hundred sheep per day. The fleece recovered from a sheep can weigh between 6 and 18 pounds (2.7 and 8.1 kilograms); as much as possible, the fleece is kept in one piece. While most sheep are still sheared by hand, new technologies have been developed that use computers and sensitive, robot-

controlled arms to do the clipping. The fleece can be removed using scissors or mechanical fleece removers.



**Picture: Shearing of sheep**

## **6.2. Grading and Sorting**

The first process at the mill is sorting. The fleece is sorted into grades by individuals who have developed a keen sense of touch. They sort the fibres according to fineness, length, and colour. Each wool product is made from a different type of fibres, and the sorter divides the fleece accordingly. Thick, short fibres are used in tweeds. Thinner fibres are used in fine wool crepes. Very soft lamb's wool is made into fine sweaters.

Grading is the breaking up of the fleece based on overall quality. After shearing, the wool is sorted. In sorting, the wool is broken up into sections of different quality fibres, from different parts of the body. The best quality of wool comes from the shoulders and sides of the sheep and is used for clothing; the lesser quality comes from the lower legs and is used to make rugs. In wool grading, high quality does not always mean high durability.

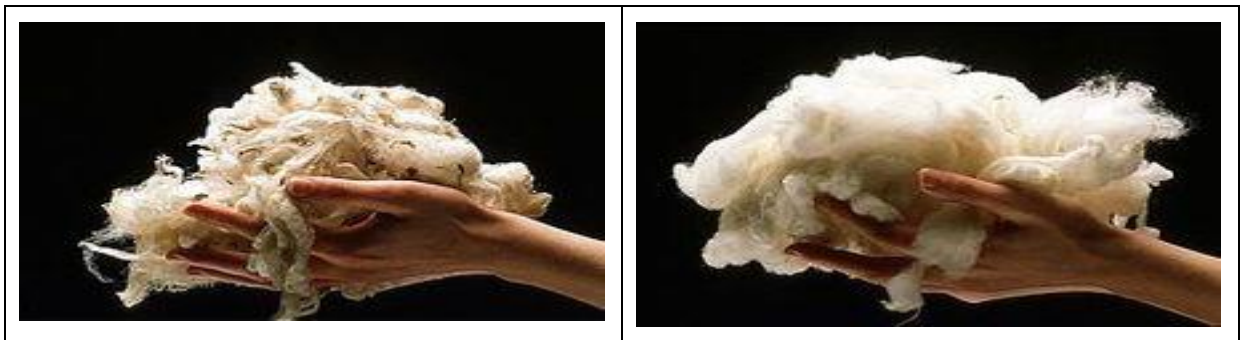

Wool from ewes, rams, and lambs must be sorted from each other and kept separately. Different quality of wool is used for wefts, warps, and piles. Therefore, while sorting wool, factors such as the length of fibres and wool's ability of absorbing dyes should be considered. Wool which is going to be the source of the yarns for pile should be supple, resilient, and soft. The quality of wool varies not only due to the different type of breeds, but it also depends on the geographic location of animals, climatic conditions of the region, the season of shearing, the quality, and composition of fodder.

### 6.3. Cleaning and Scouring

Wool taken directly from the sheep is called "raw" or "grease wool." It contains sand, dirt, grease, and dried sweat (called suint); the weight of contaminants accounts for about 30 to 70 percent of the fleece's total weight. The main purpose of scouring is to remove the impurities in wool like dust, dirt, perspiration, and natural oily matter. Without this, further processes are impossible. The process of scouring is carried out in a large machine called the scouring train. This process is carried out in different ways.



**Photo: Cleaning and Scouring of wool**

To remove these contaminants, the wool is scoured in a series of alkaline baths containing water, soap, and soda ash or a similar alkali. The by products from this process (such as lanolin) are saved and used in a variety of household products. Rollers in the scouring machines squeeze excess water from the fleece, but the fleece is not allowed to dry completely. Following this process, the wool is often treated with oil to give it increased manageability.



## 6.4. Carbonisation of Wool

Carbonization is the conversion of organic matters like plants and animal dead remains into carbon through destructive distillation. Carbonization is a process by which solid residues with increasing content of the element carbon are formed from organic material usually by pyrolysis in an inert atmosphere.

Carbonisation is performed on woollen items to remove traces of vegetable matter. The most unwanted cellulosic impurities, which remain entangled with raw wool are burrs and broken seeds of various plants. These are to be removed after the scouring process, otherwise these may damage spinning machines like card fabricating and combs. Yams with burrs are difficult to weave and dye evenly.

Sometimes scoured wool contains vegetable impurities that cannot be completely removed through mechanical operations. Sulphuric acid is the chemical substance used for destroying these vegetable particles and the process is called carbonizing. Carbonizing can be carried out on floc/loose fibre and fabric.

The process can be carried out either in conjunction with raw scouring or at the fabric processing stage, depending on the level of impurities and the end use of the wool. Carbonising consists of soaking the material in dilute sulphuric acid followed by neutralisation with sodium carbonate. The material is then dried and the brittle cellulosic matter mechanically removed. The generally low levels of organic materials in carbonisation effluents are due to vegetable matter, whilst the acid treatment yields high levels of dissolved solids. Performing carbonisation in conjunction with raw wool scouring leads to a reduction in the total pollution load of the scouring waste stream. Given the drawback of acid carbonising, such as excessive fibre damage and environmental pollution from the relatively large amount of acid used, it is not surprising that researchers are looking at the potential role of enzymes.

## 6.5. Bleaching of Wool

The natural colour of white wool varies from white to yellow. To eliminate the yellow tint, or dyeing bright pastel shades, wool must be bleached. Wool cannot be bleached with sodium hypochlorite solutions, since it is extensively damaged to the

point at which it even dissolves in the solution. The traditional method of bleaching moist wool used sulphur dioxide gas. This simple and cheap process was called stoving but is now obsolete.

Today, the most preferred bleaching agent is hydrogen peroxide. Bleaching is usually carried out in weakly alkaline solution containing a stabiliser and a sequestrant, as this gives the best quality white fibres. Even after carefully controlled alkaline bleaching of wool, the goods should not be boiled as the bleached wool is quite sensitive to yellowing.

Wool bleaching is generally carried out by oxidation, reduction or combined oxidation/reduction process

### **6.5.1. Oxidative Bleaching**

Wool is invariably bleached with hydrogen peroxide. The chlorine based oxidative bleaching agents are not suitable for wool. The alkali used for activating should be mild. The stabilizers used are phosphates, tetra sodium pyrophosphate or sodium tri polyphosphate. Since wool can be damaged under alkaline condition, an alternative is to bleach in acidic conditions using a peracid activator.

A batch treatment with hydrogen peroxide is used for most bleaching applications. Typically, wool is bleached at pH 8–9 for 1 h at 60°C with a stabilized solution of hydrogen peroxide (0.75% w/w).

### **6.5.2. Reductive Bleaching**

Reductive bleaching of wool is carried out with Thiourea dioxide, Sodium dithionite, Zinc formaldehyde sulfoxylate or Sodium formaldehyde sulfoxylate

The two most popular chemicals used for reductive bleaching of wool are stabilized sodium dithionite and thiourea dioxide. Sodium dithionite is the preferred reducing agent. Bleaching is carried out using 2-5 g/l sodium dithionite at 45-65°C at pH- 5.5-6 for 1 hour. Bleaching can also be carried out with thiourea dioxide (1-3 g/l) at 80°C and pH of 7 for 1 hour. Whiter fabric is produced when oxidative bleaching is followed by a reductive process-this is often referred as 'full bleaching'.

### **6.5.3. Combined Oxidative-Reductive Bleaching**

In this approach wool is first bleached with alkaline  $H_2O_2$  at  $60^\circ C$  for 1 hour. To the bath thiourea is added and pH adjusted to 4.5-5.5. Thiourea is converted to thiourea dioxide and bleaching is carried out at  $60^\circ C$  for another 25 min, followed by washing and rinsing.

Peroxide bleached wool has a reddish tone whereas reductively bleached wool often has a greenish tinge but a natural white is generally the demand of the industry. A sequential oxidative and reductive bleaching process is supposed to peroxide a neutral white colour.

Thus in the first stage oxidative bleaching occurs with  $H_2O_2$  and reductive bleaching takes place in the 2nd stage with thiourea dioxide.

## 6.6. Carding

Next, the fibres are passed through a series of metal teeth that straighten and blend them into slivers. Carding also removes residual dirt and other matter left in the fibres. Carded wool intended for worsted yarn is put through gilling and combing, two procedures that remove short fibres and place the longer fibres parallel to each other. From there, the sleeker slivers are compacted and thinned through a process called drawing. Carded wool to be used for woollen yarn is sent directly for spinning.



**Photo: Carding of wool**

## 6.7. Drafting and Doubling

Drafting is the process of drawing out (or attenuating) a fibrous assembly, such as a sliver, top or roving, to form a thinner strand of fibres. The result is a longer, continuous strand of fibres with a lower linear density than before, i.e. with fewer fibres in the cross-section, and the fibres are straighter and more parallel.

Drafting is required at various stages of worsted and semi-worsted yarn manufacture (i.e. gilling, combing and drawing). Roller drafting is performed by passing a sliver or roving between two pairs of driven rollers. The delivery (or front) rollers have a higher surface speed than the feed in (or back) rollers.

Doubling is the feeding of two or more ends of sliver or roving side-by-side into a drafting zone so that they are combined together and are delivered as one strand. The purpose of doubling is to promote regularity, fibre mixing and fibre alignment, as well as to maximize machine productivity.

## 6.8. Gilling

In worsted top making, the card sliver is subjected to a number of preparatory gilling or pin drafting operations prior to combing, in order to straighten and improve the parallelisation of the fibres, to provide further mixing and to reduce the fluctuations in linear density of the sliver. These steps are called preparer gilling. Further gilling steps, called finisher gilling, also occur after combing, to give a highly uniform sliver called top. Combing aligns the leading ends of the fibres, which adversely affects the sliver cohesion and subsequent processing. One of the main objectives of finisher gilling is to again randomize the leading fibre ends by drafting. Finisher gilling also provides further blending, straightening and aligning of the fibres, and the addition of moisture and oil, to produce a top of the required linear density and evenness. The first finisher operation generally involves up to 30 doublings and drafts between 5 and 10, while the second operation involves only 4 or 5 doublings.

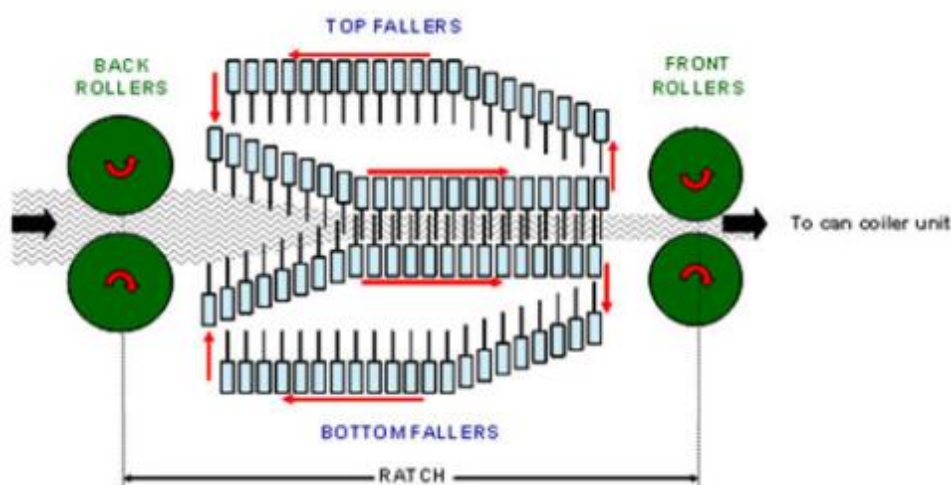

**Figure: Principles of Gillbox**



**Figure: A Gill Faller**

The fallers are metal bars with up to about 100 sharp steel pins projecting from their working surfaces and equally spaced along the length of the bars (shown in above figure). The pins may be round or flat; round pins are more robust but flat pins give better fibre control. This is because for the same number per unit length they have a larger free space within which a greater number of fibres can be held. The faller lengths are parallel to the nip lines of the front and back roller and penetrate the sliver vertically.

Gill boxes can be equipped with either mechanical or electronic auto levellers and can also be fitted with spraying devices. Adding moisture during high speed gilling is important to achieve the desired regain for subsequent processing. A lubricant (0.1-0.3%) may also be sprayed onto the sliver during the first or second gilling operations to assist in maintaining (or increasing) regain, minimizing static effects and modifying the fibre-to-fibre cohesion. Integrated suction and blowing systems keep the heads clean.

A number of slivers (doublings) pass between the back rollers (or feed rollers), merge into one sliver and are progressively penetrated and held between pins mounted on the fallers. Upper and lower sets of intersecting fallers move forward towards the front rollers (or delivery rollers) at a slightly higher linear speed than the surface speed of the back rollers. This speed difference applies a tension to the sliver. At the end of its travel each faller is withdrawn and transported back to the starting point where it gradually re-penetrates the fibres as it moves forward again. The front rollers operate at a faster surface speed than the back rollers so the sliver is drafted to produce a sliver of the required linear density. Typical drafts of 5 – 15 are used.

The length of the drafting zone, the distance between the nip lines of the front and back rollers, is called the ratch. Although the back ratch draft gives only a small amount of straightening, it is still important. If the draft in this zone is too high, the

combing action of the faller pins may result in fibre breakage, and irregularities may occur because of the uncontrolled motion of the short lengths of broken fibres.

On the other hand, if the draft in the back ratch drafting zone is too low, the fibres may not be sufficiently extended to remove their natural crimp. The drafting force in the front ratch zone then reaches a level that is sufficient to break fibres, owing to the greater frictional resistance caused by the crimp retained by the fibres. The pins are used in fibre control in that they assist in maintaining inter-fibre friction. This function, in conjunction with their restrictive effect, minimises any forward, out-of-turn movement not gripped by the front rollers. In addition, the fibres being withdrawn have their trailing ends combed by the pins, greatly accelerating the straightening and parallelisation action.



**Photo: Gill Box**

## **6.9. Spinning**

After being carded, the wool fibres are spun into yarn. Spinning for woollen yarns is typically done on a mule spinning machine, while worsted yarns can be spun on any number of spinning machines. After the yarn is spun, it is wrapped around bobbins, cones, or commercial drums.

Thread is formed by spinning the fibres together to form one strand of yarn; the strand is spun with two, three, or four other strands. Since the fibres cling and stick to one another, it is fairly easy to join, extend, and spin wool into yarn. Spinning for woollen yarns is typically done on a mule spinning machine, while worsted yarns

can be spun on any number of spinning machines. After the yarn is spun, it is wrapped around bobbins, cones, or commercial drums.

## **6.10. Weaving**

Next, the wool yarn is woven into fabric. Wool manufacturers use two basic weaves: the plain weave and the twill. Woollen yarns are made into fabric using a plain weave (rarely a twill), which produces a fabric of a somewhat looser weave and a soft surface (due to napping) with little or no luster. The napping often conceals flaws in construction.

Worsted yarns can create fine fabrics with exquisite patterns using a twill weave. The result is a more tightly woven, smooth fabric. Better constructed, worsteds are more durable than woollens and therefore more costly.

## **6.11. Finishing**

After weaving, both worsteds and woollens undergo a series of finishing procedures including: fulling (immersing the fabric in water to make the fibres interlock); crabbing (permanently setting the interlock); decatizing (shrink-proofing); and, occasionally, dyeing. Although wool fibres can be dyed before the carding process, dyeing can also be done after the wool has been woven into fabric.

## Chapter 7

### CLEANING AND SCOURING OF WOOL

#### 7.1. Contaminants of Wool

Wool is perceived to be a clean, green, natural fibre. However, raw or 'greasy' wool is contaminated with natural impurities, the type and level depending on the breed of sheep, and the conditions under which the wool is grown. These impurities, which may be up to 40% (or more) by weight, must be washed off before the wool can be used as a textile fibre.

The main contaminants are wool grease, suint and dirt. Wool grease, which is really a wax, is a complex mixture of organic compounds called esters. It is produced by the sebaceous glands in the skin of the sheep and occurs as a stable solid or semi-solid film around the fibre with a melting point around 43°C. While wool grease is insoluble in water, a solution of water and detergent forms an emulsion with wool grease to facilitate its removal from the fibre.

Wool grease is soluble in organic solvents such as ethanol and dichloromethane. The amount of wool grease (or wax) present on the wool depends mostly on the sheep breed, with merinos recording the highest amounts.

Suint, which is produced by the sudiferous (sweat) glands of the sheep, is dried sweat, consisting mainly potassium salts of organic acids. In wool scouring liquors, at alkaline pH levels, suint has detergent properties. The amount of suint also depends on the breed of sheep, with crossbred wools tending to have higher levels than merino wools.

A third category of contamination acquired by the fleece is termed surface soiling, which includes dirt, dust, faeces and vegetable matter (VM) such as burrs picked up when the sheep is grazing. .

If the level of VM contamination is high the wool may have to be carbonised to remove it. Certain types of VM are more troublesome than other types and must be removed. A major proportion of the wools requiring carbonising are from Australia and South Africa.



Table below shows typical contaminant levels in the major Australian and New Zealand sheep breeds.

Typical concentrations of wool contaminants

	Maximum	Minimum	Average
<b>Australian (New South Wales) Merino</b>			
<b>Grease</b>	25.4	10.0	16.1
<b>Suint</b>	12.0	2.0	6.1
<b>Dirt</b>	43.8	6.3	19.6
<b>New Zealand crossbred</b>			
<b>Grease</b>	8.5	1.6	5.2
<b>Suint</b>	12.1	2.2	8.0
<b>Dirt + suint moisture</b>	—	—	7.9

The wide differences in the types and levels of wool contaminants help to explain why different machinery and processes have proved necessary in wool scouring. For example, the large amount of fine dirt on some of the fine wools from Western Australia is very difficult to remove and thus low scouring throughputs are often necessary. On the other hand, high-yielding coarse wool from New Zealand represents the other extreme in being relatively easy to scour with high production rates possible.

While as much contamination as possible is removed as wool grease or sludge, a significant proportion of the contaminants removed from the wool is discharged from the wool scour as an aqueous effluent. The organic effluent load from a typical wool scour is similar to that of the sewerage from a town of 30,000 people.

## 7.2. The objectives of wool scouring

The principal objectives of modern wool scouring are to remove all wool contaminants at maximum efficiency, with efficient energy utilisation and with

minimum impact on the environment. Quality control objectives for the scoured product are:

- To produce clean wool of consistently good colour, without causing excessive entanglement
- Achieving a specified moisture regain by efficient drying
- Achieving an acceptably low residual grease and dirt content
- To achieve a correct wool pH level (appropriate for subsequent dyeing).

The factors that are important in achieving a clean, bright scoured product are:

- Degree of opening given before scouring
- Number of bowls in scouring line
- Detergent and builders used
- Water quality
- Time of immersion in the bowls
- Temperature of scouring bowls
- Amount of mechanical action used
- Efficiency of the squeeze presses.

The critical importance of scouring as the first step in processing wool has always been appreciated, although the incentives to the development of new or improved scouring systems have changed over the years.

### **7.3. Methods of Wool Scouring**

From chemical point of view, there are various methods of purifying loose wool and these are determined to some extent by the type of material to be cleaned, and the nature and amount of the impurities. The main methods of purification/scouring are:

1. Freezing
2. Solvent Scouring
3. Detergent Scouring

### **7.3.1. Freezing Process**

A partial cleaning of wool is possible by freezing technique. The freezing process for removal of dirt and grease consists of passing the wool, after dusting, through low temperature chamber in which the moisture is frozen and the grease solidified. When raw greasy wool is cooled to a temperature of  $-30^{\circ}$  to  $-45^{\circ}\text{C}$ , the fats freeze and become hard and brittle, After freezing the dirt and fibres are separated mechanically and the amount of organic matter to be removed by subsequent washing of the fibres thus reduced.

The raw wool is fed into the top of a refrigerator through a pair of rollers, which act as a seal. The wool falls on a conveyor and is allowed to stay in the chamber for about 3-7 minutes, and is then passed on a cleaning machine, which comprises a cylinder with steel pegs on its surface.

Some fibre breakage may occur due to mechanical treatment, but after milder scouring, a softer handle, lofty appearance and better colour is obtained as compared to conventionally scoured material. This is patented process has not been found generally acceptable as the quality of after this process has not been considered satisfactory.

### **7.3.2. Solvent Scouring**

Solvent scouring consists of opening the wool, dusting and then treating the wool in batches or continuously, using solvent to remove the grease and then scouring the wool in a light soap and soda wash. The used solvent is redistilled and returned to the process and the grease is recovered.

Organic solvents are used to extract wool wax commercially in a limited scale. The process may be costlier than aqueous scouring, the advantages are lesser felting and lesser entanglement of wool, and complete separation of the wax without contamination with fatty acids derived from soap used in aqueous scouring. However, solvents do not remove suint and dirt and an additional step of aqueous scouring is necessary. Wool wax may be removed from wool by benzene, carbon tetrachloride, solvent naphtha or white spirit. Chlorinated hydrocarbon solvents are convenient, but usually cheaper petroleum solvents of high boiling point are used.

The latter require adequate precautions against fire. Solvent scouring of wool can also be carried out using perchloroethylene in which 8-18% water on the weight of wool has been emulsified with a surfactant. Solvent and wax may be separated by distillation and the solvent is reused. In spite of significantly higher yield, the wax is of less commercial use due to its brown colour.

In conventional method, wool is packed into a kier, which is evacuated of air and the solvent is introduced. The extraction is effected in three stages, first with a solvent that has been already used for the scouring purpose twice, then with a solvent used once, and finally with a fresh solvent. The residual solvent on wool is removed by blowing warm air through the kier, and passing it through a condenser where the solvent is recovered. The suint is not removed by solvent treatment and, therefore, an additional treatment with warm water in a special bowl or de-suinting machine is necessary.

### **7.3.3. Detergent Scouring**

Detergents are cleansing agents and they contain surfactants. The term surfactant is the abbreviated form of surface active agent. A surfactant is a substance that reduces the interfacial tension between water and other liquids. Surfactants are used widely in textile processing in many forms, including wetting agents, emulsifiers, and detergents.

Wool wax is difficult to saponify under conditions, which would not damage the wool fibres. However, it may be readily emulsified, particularly at a temperature slightly higher than its melting point (40-45°C). Emulsion scouring with soap is the most common method of cleaning loose wool. Scouring, most popularly known as wool washing, is done with 2-4% soap and 2% sodium carbonate, calculated on the weight of the wool.

At present, wool scouring is most economically done with non-ionic detergents. After emulsion scouring, the separated wool wax is contaminated with detergent and suint. For this reason, the product is called wool grease, as distinct from wool wax. In detergent scouring, the wool is first subjected to opening and dusting, preparatory to the scouring process. Considerable dirt amounting to 5 to 15% of the total impurities is removed in this step and disposed of in a dry condition.

The opened and dusted wool is fed into a scouring machine and conveyed by moving rakes through two to five bowls containing a warm soap and soda solution maintained at about 50°C. The first bowl in a four or five bowl machine may be filled with warm water only and used as a de-suinting bowl. The final bowl is used for rising and operates with a continuous flow of clean water. After rinsing the wool may be bleached, blued or carbonized before going to subsequent dyeing and finishing operations.

Wool scouring liquors are handled differently in different plants. Generally the scouring liquor is pumped continuously or periodically counter-current to the flow of wool, and then removed from the first scouring bowl to centrifuges where grease and dirt are removed and the centrifuge effluent returned to the scouring machine. Hoppers under the bowls, which collect sand and dirt, are dropped intermittently to waste. Complete dropping of the scouring bowl may take place over any period of from one day to one week. The de-suinting bowl is usually dropped daily. These wastes, together with the continuous flow from the rinse bowl, leaks, and floor wash, make up the source of scouring liquor wastes.

When the detergent molecules meet the layer of grease on wool fibres, the tails are drawn into the grease but the heads remain immersed in the water. The attractive forces between the head groups and the water are so strong that the grease is lifted away from the surface. The micelle is now completely surrounded by detergent molecules and is washed away by the water.

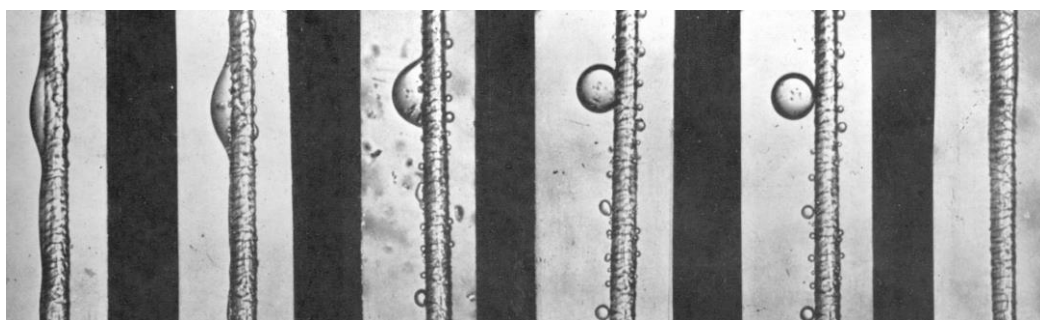

**A**

**B**

**C**

**D**

**E**

**F**

***Image: Detergent action to removal of grease from a fibre by detergent***

The stages of grease removal in the scouring bowl are:

- A. Wool grease present on wool fibre.

- B. Water is heated to above the melting point of wool grease, which is about 40°C. The heated wool grease forms a stable film over the surface of the fibre. The scouring liquor wets the fibre.
- C. Surfactant molecules from the detergent cover the film of grease. Surfactant molecules on the wetted fibre reduce the attraction of the grease to the fibre. The grease rolls up into droplets.
- D. The water attracted to these molecules pushes between the fibre and the grease droplet. This helps to detach the grease droplet
- E. Agitation by the harrows and the high-speed liquor flow at the squeeze rollers transport the grease droplets away from the fibre.
- F. Clean grease free wool fibre.

#### **7.3.4. Bio-scouring**

In aqueous scouring treatment, the high scouring temperature (60-90°C) wasted excessive heat energy and there was too much organic solvent to demolition in the solvent-scouring waste water. In order to resolve the complications, enzymatic bio-scouring treatment is a recent evaluation in wool pre-treatment process. The enzyme with acceptable bi-scouring effect was a combination of *Bacillus subtilis* and *Candida lipolytica*. Enzymatic bio-scouring can be carried out with about 6% enzyme concentration at pH 7 and temperature 40-45°C.

#### **7.3.5. Scouring of Wool by Low Temperature Plasma Treatment**

In order to enhance the effectiveness of scouring process, plasma treatment as environmentally friendly technique have employed in wool fabric nowadays. Oxygen gas can be used as plasma gas. Since this process is highly sophisticated, it is not yet widely practised.

## Chapter 8

### WOOL FIBRE SCOURING

Wool can be scoured in fibre or yarn or fabric form. However, wool is normally scoured in fibre form.

#### 8.1. Wool fibre scouring machines

Wool fibre scouring machines are of three types.

1. Swing Rake machine
2. Harrow machine
3. Paddle machine

The first two are widely used in England and other Western countries, while the latter is a continental system for scouring shorter and dirtier wool. In the first two English methods, a number of prongs move raw wool continuously through a series of shallow bowls or rectangular tank filled with the scouring liquor. Each bowl is fitted with a perforated false bottom over which the material moves.

##### 8.1.1. Swing Rake machine

In the swing rake machine, individual prongs or rakes move separately and cause greater degree of agitation. The forks are moved by cam and crank arrangement in such a manner that the prongs first descend into the liquor and press the wool down. They then move gently horizontally carrying wool through the liquor. At the end of the sweep, they rise vertically out of the liquor and return to the original position. The usual length of sweep is about 9 inches, but sometimes a 12 inch sweep is used. The swing rake machine cleanses dirty wool better; vigorous mechanical action is liable to cause some degree of felting or matting of the fibres. The rakes can be adjusted to act in unison or may be timed to exert an individual sweeping movement by operating at different periods. This irregular motion brings about more agitation of wool and so

produces better cleaning action, but only suited for coarse wool. Fine wool may tend to felt if severely treated and the fibres break during subsequent mechanical processing.

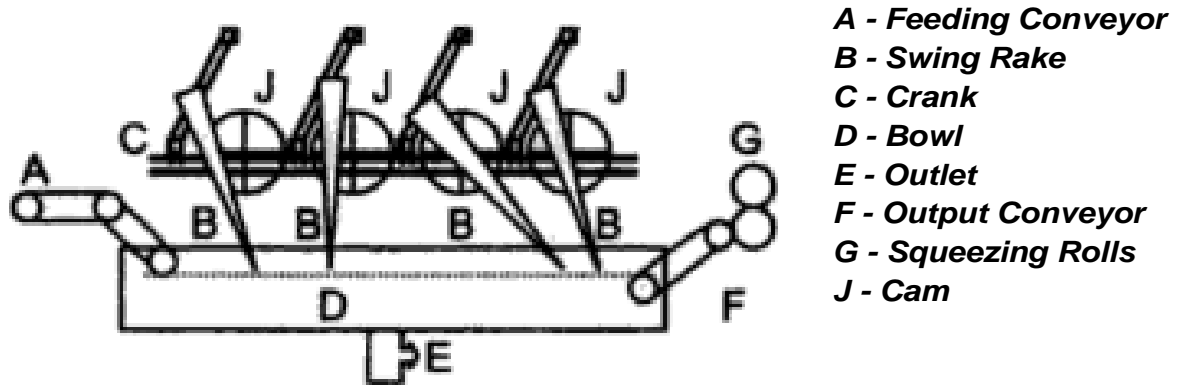

**Figure: Swing Rake Machine**

### 8.1.2. Harrow machine

In the harrow machine, the prongs are all mounted on one frame called harrow and moves together. This provides comparatively gentle form of propulsion and is, therefore particularly suitable for finer qualities of wool, which felts easily. Some systems of scouring raw wool of medium quality include both methods, first the swing rake and then the harrow.

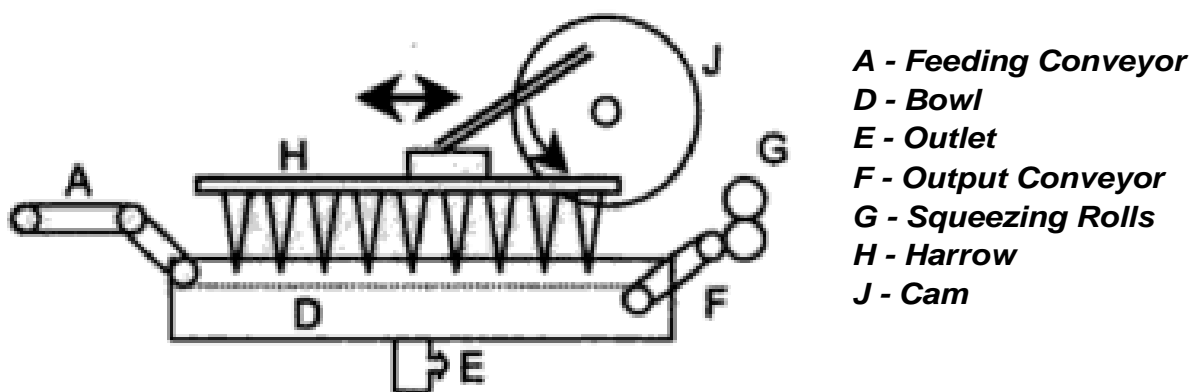

**Figure: Harrow Machine – Wool Fibre Scouring**

In conventional method, the paddle action gently swishes the wool along the bowl in which it has a longer period of immersion at much lower temperature than in the English method. The continental system is a closer



approximation to true emulsification. In the English method, the wool wax is partly removed by melting with subsequent wash. The English system operates at a temperature of 50°C to 55°C for a total period of 10 to 15 minutes, whereas in the continental method the temperature is 28-38°C and the time of treatment is longer (20 to 25 minutes).

As the wool enters each bowl, it is pushed under the surface to wet it thoroughly with the liquor in that bowl. A set of metal teeth (rakes or harrows) gently drags the wool through the liquor, as shown in Figure below. When the wool reaches the other end of the bowl it is lifted up into a pair of rollers that squeeze the liquor out of it. The wool is then dropped into the next bowl where the process is repeated.

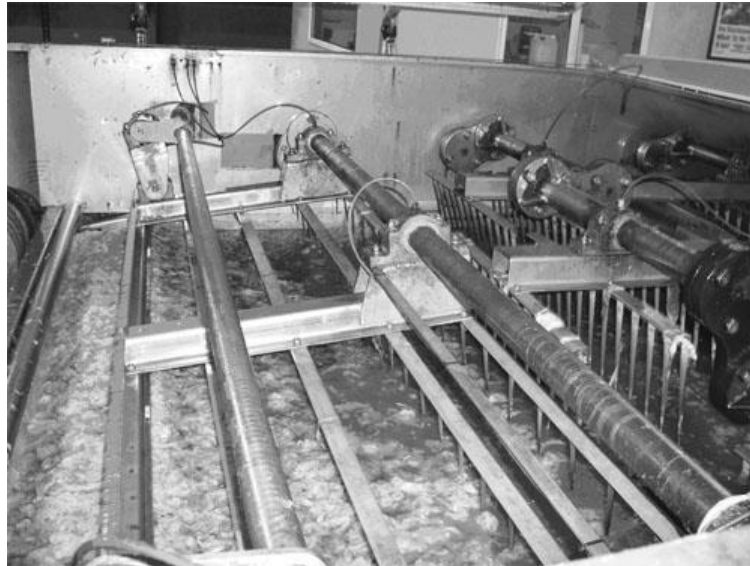

***Figure: Immersed wool being moved by the rakes in a scouring bowl.***

The suint dissolves quickly in the first bowl while the wax and dirt particles are steadily removed by a combination of detergent action, mechanical agitation and gravity, and by the pressure applied by the squeeze rollers. As the wool moves through the bowls it becomes cleaner, and moves into cleaner liquor.

The liquor flows in the reverse direction to the wool movement and is discharged from the first bowl for treatment. Wool grease is extracted from this effluent and refined for a variety of uses.

Finally, the wool is rinsed to remove the detergent and to eliminate the remaining solids. The first rinse is normally done with copious quantities of cold water, followed by a final rinse in hot water before drying.

### 8.1.3. Paddle machine

In this machine, wool is conveyed through the scouring bowl by a series of suction drums. The feeding device (A) for the bowls (D) generally consists of an endless blanket made of leather or lattice wire on which the wool is evenly spread. The greasy wool tends to float in the liquor. Hence, an immersion roller or box called ducker is fixed at the entry into liquor. The roller or the box is perforated and is placed beneath the liquor. The wool is forced to dip into the liquor and is moved forward.

At the end of the bowl, the wool has to be carried forward and upward to the squeezing rollers (G) by an accessory called Lift. This operates like a small grab- some of its forks dipping into the wool and lifting it onto a small conveyor (F), which carries it to the nip of the rollers. An alternate technique, side lift consists of a series of slides with projecting spikes, which carry the wool to the squeezing roller. Now the most common transfer mechanism is the wash plate. Scouring liquor overflows from the bowl and washes the wool down a plate inclined towards the squeezing bowls. The wash plate is perforated at its end to assist drainage of liquor from the wool.

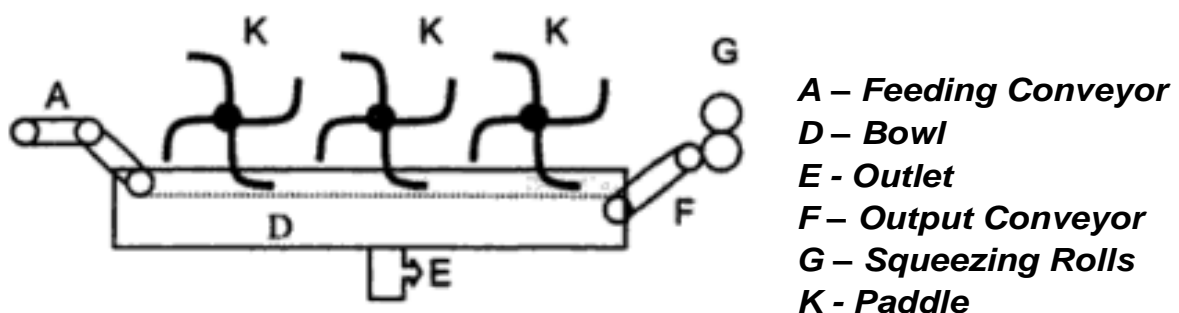

**Figure: Paddle machine**

The function of intermediate squeezing is to minimise the carry-over of liquor from one bowl to the next. Where water usage is high, the amount of carry-over has little effect. However, in modern plants with water usage less than 5 litres per kg, the carry-over has an important effect on overall scouring

effectiveness. The bottom roller is always metal (stainless steel) usually knurled or otherwise roughened to assist in gripping of wool. The top roller may be covered with a resilient material such as rubber or polyurethane, lapped with several layers of wool or other fibrous material.

In all three systems, the wool is scoured in troughs or bowls with perforated false bottoms, which permit the heavy impurities to escape, by settling into the compartment at the bottom of the bowl. Side compartments are provided at the end of the bowl, to receive the liquor from the squeezing rollers. As the dirt settles and the fats rise, the intermediate purer liquor may be fed back into the bowl for reuse. Modern scouring machines designed for the middle range of merino wool are typically six bowls long. A conventional five bowl scouring machine is shown in Figure below.

## 8.2. Conventional Wool Scouring Machine

Nearly all scouring machines would have three scouring bowls, i.e. bowls in which the bulk of the contaminants are removed. The remaining one or two bowls would be rinse bowls to which no detergent is added. In the ideal system, the first bowl cannot be a suint bowl, since the purpose of a suint bowl is negated if it receives counter-current flow of hot detergent liquor from the second bowl. However, it is possible to add a suint bowl to the front of an ideal system.

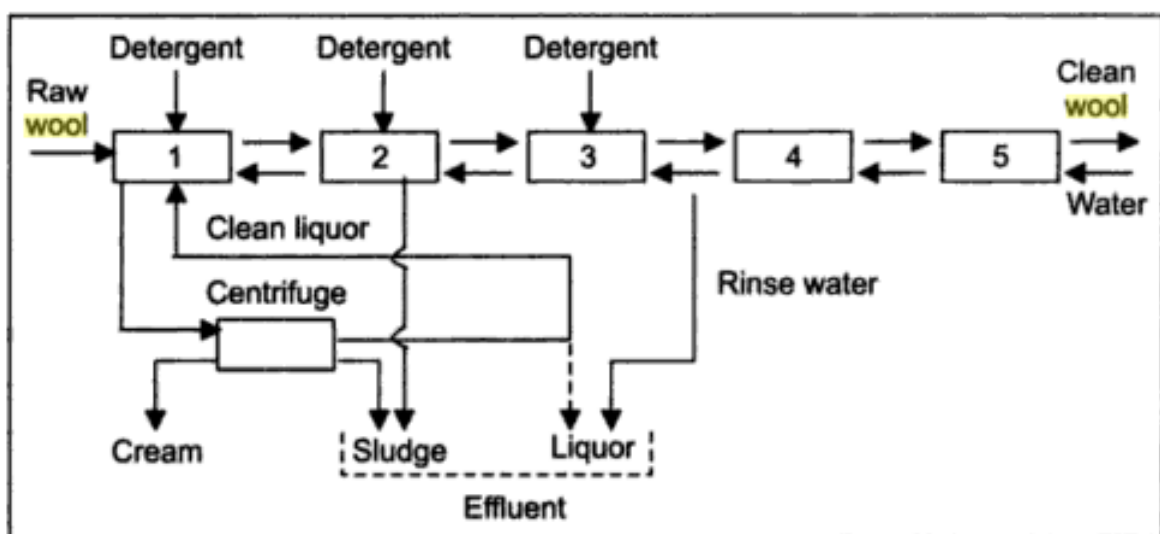

**Figure: Conventional five bowl scouring machine**

The successive bowls of a set are generally arranged in one straight line. Many types of bowls are available and in some of them, it is possible to impart additional motion to the rakes, opening the wool and agitating it during the scour. The process must be gentle to avoid felting and owes a great deal of its efficiency to the open nature of the loose wool, which assists penetration and permits the escape of the scouring liquor.

The first bowl is responsible for the major part of the cleaning and the later bowl for further cleaning and rinsing of wool. The bowls mostly operate in counter current principle. When the scouring liquor in the first bowl becomes too dirty for further use, it is withdrawn from time to time or continuously drained through the outlet. When self-cleaning bowls are not used, the first bowl is to be emptied out after every 24 hours and refilled with liquor from the second bowl followed by strength adjustments of the scouring agents.

For an ideal steady-state system, water, introduced at the last bowl, flows back successively to the previous bowls and finally dirty water is discharged from the first bowl. However, if a self-cleaning device is attached to the bowl, the scouring liquor will be cleaner.

The dirty liquor from the first bowl may be clarified by a centrifuge and used again. The liquor may be taken to the centrifuge, where cream, dear water and sludge are separated as top, middle and bottom layers respectively. Usually, cream production from the centrifuge is controlled by setting the size of the gravity disk, a dam over which the middle layer flows. The cream is treated with boiling water and is sent to the clarifier centrifuge for separating wool grease. The clear liquor after filtration may be send back to the bowl, while sludge to the sludge-bed of effluent treatment plant. Dirty-water from the centrifuge as well as rinsing water from fourth bowl is sent to the effluent treatment plant. Advantage can be taken of the contaminant removal device by reducing either the number of bowls or the counter-current flow rate. Some of the important operating relationships in the ideal system are:

1. The higher the number of bowls, the lower the counter-current flow rate required.
2. The more efficient the contaminant removal device, the lower the counter-current flow rate required (or the smaller the number of bowls required).
3. The effects will be same as above when the flow rate round the contaminant removal loop is greater.

In practice, the approach to the ideal system is limited by several factors. Although good scouring is possible in machines with 1 to 3 bowls, the consumption of detergent, water and heat are high. In order to reduce water consumption, nowadays, very small bowls are used in higher numbers (seven or more).



***Photo: Wool fibre scouring Plant***

The process of scoring wool involves the removal of contaminants before the greasy wool can be processed. This is the very first process that is required in order to manufacture high end quality woollen products that will last for years on end. Once the contaminants are removed, the wool is then fed into a machine where it is continuously moved through a series bowls (normally somewhere between 6-8 bowls) with wash liquor.

### 8.3. Back Washing

Although wool is cleaned or scoured in the form of loose fibre, the sliver or fibre strand prepared by the carding machine often possesses a dirty appearance. A subsequent washing treatment called back washing is necessary. After carding, the fibres are more uniformly distributed. The fibres in the carded sliver present a better form for cleaning the inadequately cleaned wool and the dirt from the interior of the fibrous lumps are accessible in case of sliver. The wool also acquires dirt during mechanical operations up to the carding stage.

The back washing plant consists of a small two-bowl scouring machine equipped with a continuous drying system and a gill box to apply oil. The first bowl consists of soap and hot water and occasionally little ammonia. A mild cleaning takes place. A second bowl containing hot water is placed a little above the first bowl and the liquor is allowed to flow to the first.

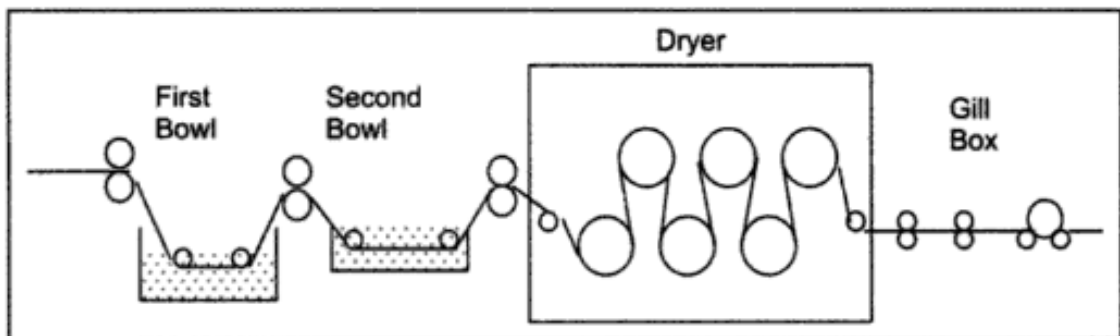
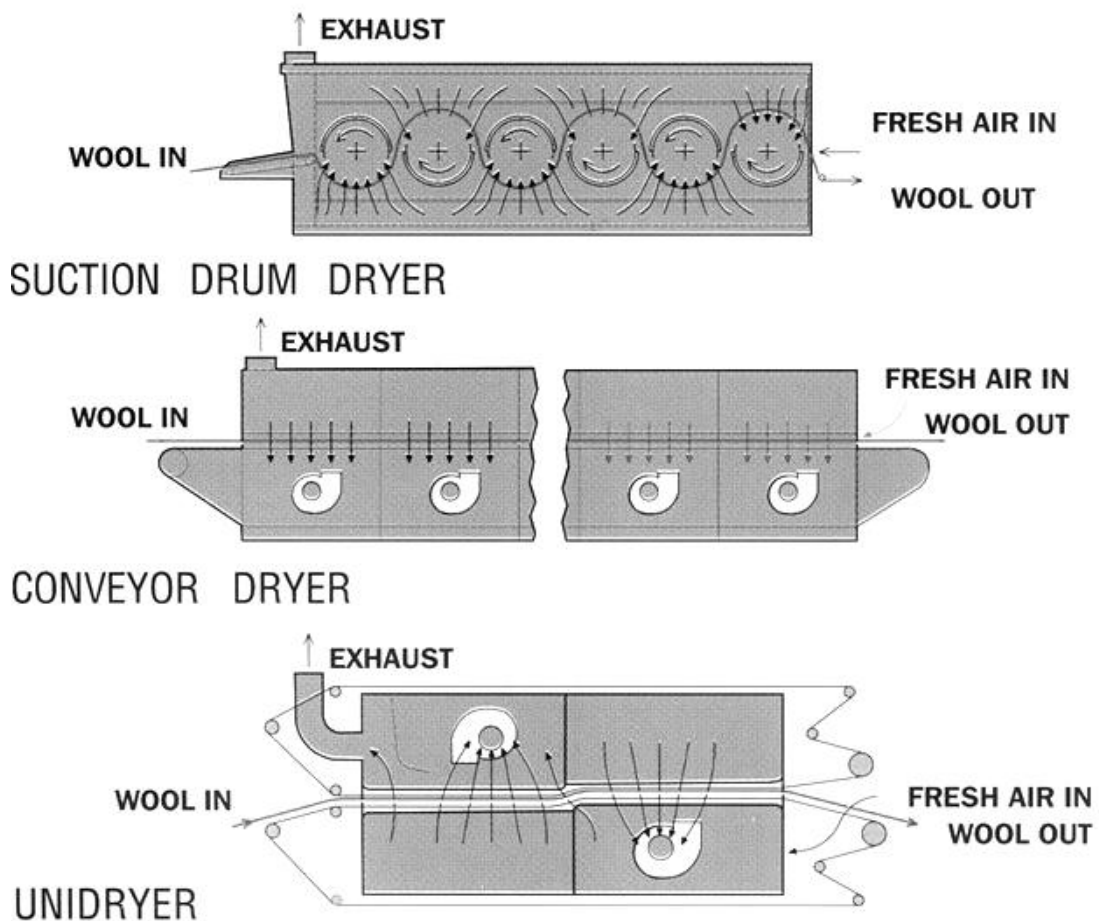

**Figure: Back Washing Plant**

The dryer consists of a steam-heated cylinder or perforated cylinder through which hot air is passed. Generally, the dryer consists of about six standard size cylinders, or in multi-cylinder machines with about 40 small cylinders of 4-inch diameter fitted around a large cylinder. Hot-air dryer without cylinder is also used. After back washing, the fibre may become brittle due to insufficient residual grease. About 3 % of a suitable oil-emulsion is applied in the gill box to protect wool during subsequent operations.

## 8.4. Drying of Wool fibres

Drying is a crucial part of wool scouring. Once the wool has been squeezed for the final time it may still hold 50% water (by weight). The wool is dried by hot air in a chamber, with the drying process being monitored by a computer-controlled sensing system that ensures that the required moisture level (or regain) is maintained. Figure below shows the three main types of dryers used in wool scouring: suction drum, conveyor dryer and Unidryer.



**Figure: Dryers used in wool scouring**

## Chapter 9

### **WOOL FIBRE SCOURING MACHINE OPERATING**

#### **9.1. Scouring of wool fibres**

Wool fibres are normally scoured in 4 steps namely (1) Soap treatment (2) Washing (3) Neutalisation (4) Drying

Mostly wool fibre are imported from Australia, Kenya, Africa and New Zealand. About 95% of wool is imported from Australia. The wool fibres obtained from shearing of sheeps are generally greasy and dirty as shown in Picture above.



***Photo: Raw wool (in Loose and Bale form)***



Raw wool bales are opened and wool fibres are fed to the scouring machine with the help of conveyor. Wool fibres are carried forward with the belt. At the end of conveyor belt there is a roller having small spikes which opens up the fibre in order to facilitate the scouring operation.



***Photo: Feeding of raw wool (wool fibre scouring machine)***

In the above scouring machine, the prongs are all mounted on one frame and moves together. This provides comparatively gentle form of propulsion and is, therefore particularly suitable for finer qualities of wool, which felts easily. The wool fibres are gently stirred and moved forward.



***Photo: wool fibre scouring(1)***

A set of metal teeth (rakes or harrows) gently drags the wool through the liquor, as shown in Picture above. When the wool reaches the other end of the bowl it is lifted up into a pair of rollers that squeeze the liquor out of it. The wool is then dropped into the next bowl where the process is repeated.



***Photo: wool fibre scouring (2)***

There is intermediate squeezing between the two bowls. Wool fibres are treated with scouring agent and stirring is carried out with the help of rakes (metal teeth) in order to achieve proper scouring. After treatments in one bowl, the fibres are squeezed with larger padding rolls to remove loosened impurities along with scouring liquor and sent to the next bowl.



***Photo: wool fibre scouring (after scouring in first Bowl the fibres are squeezed and forwardd to second Bowl)***

As the wool enters each bowl, it is pushed under the surface to wet it thoroughly with the liquor in that bowl. When the wool reaches the other end of the bowl it is lifted up into a pair of rollers that squeeze the liquor out of it.



*Photo: Wool scouring bowl*



***Photo: Wool fibre scouring (after scouring in first Bowl the fibres are squeezed and forwardd to second Bowl)***

Normally six bowls are used for complete scouring of wool fibres. The treatment in each bowl is different and it is carried out in the following sequence.

**Bowl 1:**

Initially water is filled into the trough of the bowl and required amount of soap solution is added. The temperature is raised to 70°C and wool fibres are immersed into the soap solution. During running, 70 ml/minute of 250 g/l is added. Also 1.5 kg soap per hour is added.

**Bowl 2:**

After soap treatment in bowl 1, wool fibres are squeezed and carried to bowl 2. In bowl 2, again the fibres are treated with soap solution at 70°C. Thus two bowls are used for soap scouring of wool.

**Bowl 3:**

After soap treatment in bowl 1 and 2, wool fibres are squeezed and carried to bowl 3, where fibres are washed with water at 70°C for about 50 min. Then fibres are squeezed and sent to bowl 4.

**Bowl 4:** Similar to bowl 3, wool fibres are washed with water at about 63°C for about 10 min. Thus Bowls 3 and 4 are used for washing purpose. After proper washing, wool fibres are squeezed and carried to Bowl 5.

**Bowl 5:**

In bowl 5, wool fibres are neutralised with acetic acid. Acetic acid is added at rate of 18 ml per minute. For neutralisation the temperature maintained is about 60°C.

**Bowl 6:**

This is the last bowl, where whitening of wool fibres is carried out. For whitening the wool fibres are treated with whitening agent using a dose of 6 kg per hour. Whitening is carried out at 60°C. Finally after squeezing, wool fibres are sent for drying.

## 9.2. Drying of wool fibres

After complete scouring, washing and whitening, the wool fibres are sent to dryer for drying.

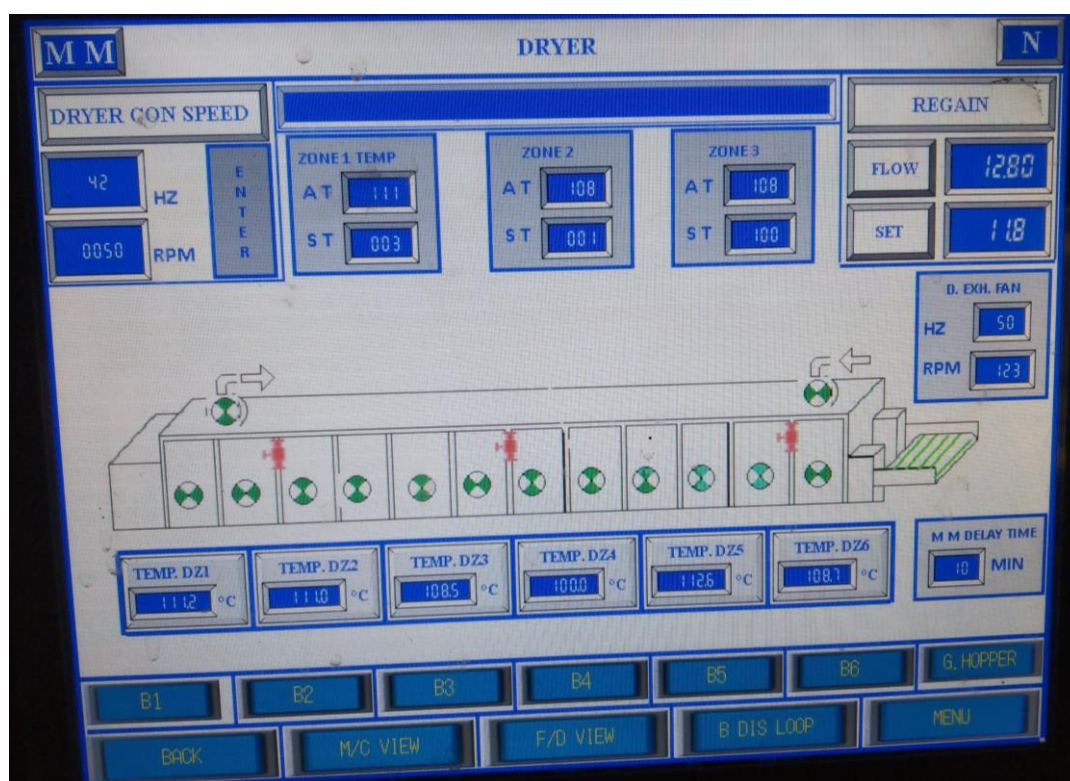

**Photo: Digital panel of drying machine**

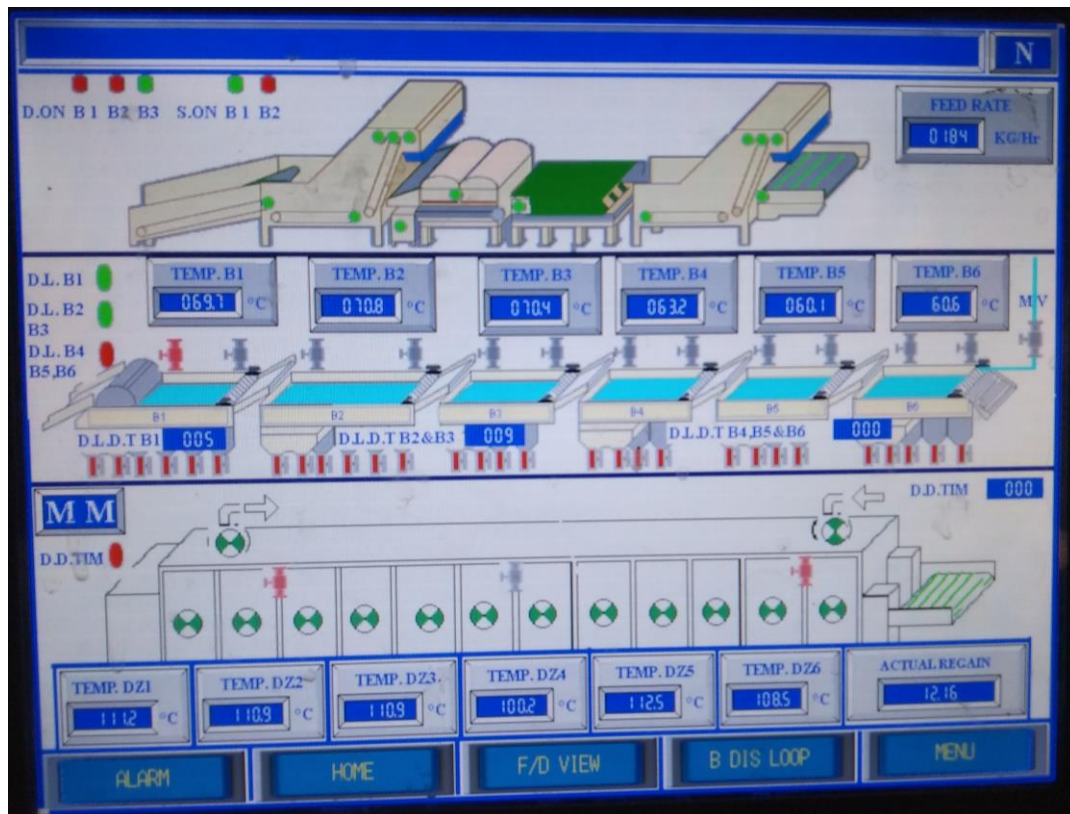

**Photo: Panel – Flow diagram of feed unit, bowls and drying of wool scouring machine**

There are six drying chambers as shown in Picture above. Wool fibres are dried with circulating hot air with help of fans.



**Photo: Wool fibres drying machine (1)**



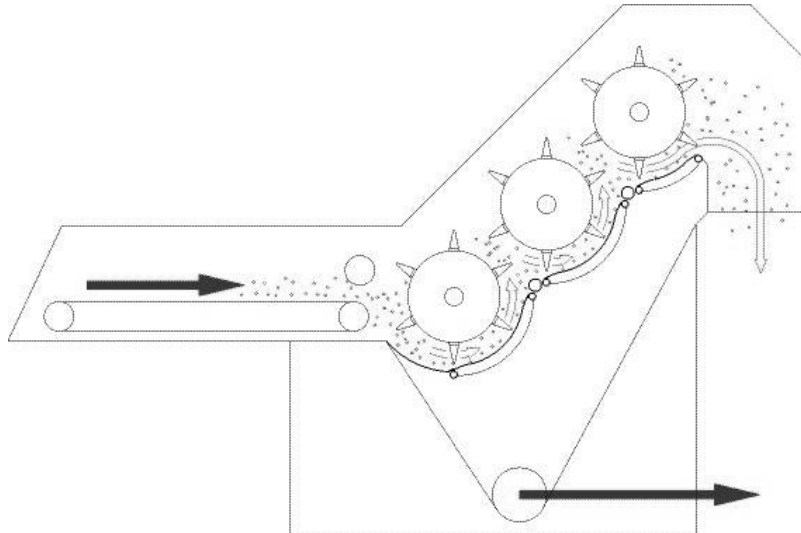

***Photo: Wool fibres drying machine (2)***

Wool fibres are placed on endless conveyor which passes through closed chambers. Wool fibres are led on the conveyor and carried forward with moving conveyor belt. The average temperature maintained in all the chambers is about 100-110°C. At the end of drying chamber the moisture maintained is about 12 %. After drying fibres are sent for further processing.

### **9.3. Handling of Scoured Wool**

Dried, scoured wool may be further processed, mainly to remove any dust remaining and to provide further opening and blending. A widely used cleaning machine is the stepped opener blender, as shown in Figure below. As the wool is moved up the 'steps' by the spiked rollers, the dust falls through perforated screens and is removed by a vacuum duct.



**Figure: Stepped opener blender.**



**Photo: Stepped Cleaner**

After passing wool fibre through stepped cleaner, fibres are sprayed with antistatic agent in order to facilitate the carding and further processing.



***Photo: Spraying of antistatic agent***

Finally, the fibre must be either packaged for shipping to a mill, or presented to the next stage of production. If the scoured wool is to be moved within a plant, conveyors or pneumatic ducting are used. Alternatively, wool may be pressed into farm bales (around 130 kg) or into high density bales (300-450 kg).

Packaging scoured wool in high density bales, restrained by steel bands, minimises the volume that each bale occupies in a shipping container and hence reduces transportation costs. The bale wrapper, which is a nylon or polypropylene fabric, protects the wool from soiling and contamination until the bale is opened for subsequent processing.

## Chapter 10

### WOOLLEN YARN SCOURING

A high proportion of wool is dyed in the yam form for the production of woven fabrics with coloured designs. These yarns are, therefore, to be scoured in yam form.

Some types of woollen yam tend to curl and distort during the scouring process and others may be entangled or felted. Hence, some permanent set is to be imparted to the yam before scouring. The commonest method is to stretch the yam on a frame and then immerse it in boiling water, or treat it with steam for 30 to 60 minutes followed by cooling in stretched condition.

Yarn may be scoured in hank form or in packages such as cones and cheeses. Various methods may be adopted for scouring of woollen hanks. The frames used for permanent setting may be lowered into the scouring liquor and the hanks are rotated by some mechanism. Subsequently the same bowl may be used for dyeing. Alternately, an endless rope or chain of hanks may be made and scouring is carried out in Dolly scouring machine as in case of piece goods.

Large-scale scouring of wool in hank form may be done in tape or brattice scouring.

#### 10.1. Tape Scouring Machine

The tape scouring machine is simpler in construction, cheaper and ideal for small batches. The hanks are trapped between the upper and lower members of two endless tape belts (T1 and T2) and are passed through two or three consecutive bowls (B1 and B2) containing detergent solution and rinsing water. A series of nip rollers (N) situated inside the liquor promotes removal of the oil and dirt. Pairs of heavy rollers (H) are placed at the entry and exit of each bowl to keep the belts in position and to squeeze out the excess liquor. The duration of treatment in the bowl is short and, therefore, a detergent of high emulsifying power and solubility should be used.

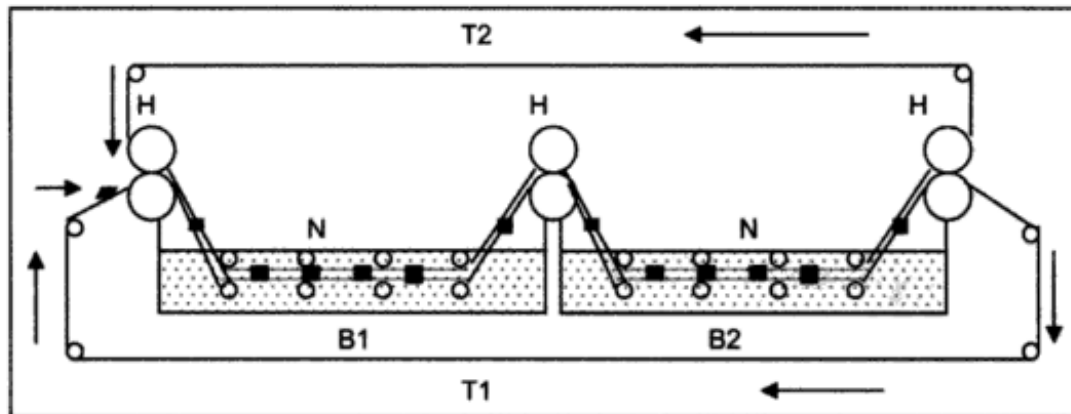

**Figure: Tape Scouring Machine**

**B1 & B2 - Bowls; H - Heavy Squeezing Rolls; N - Nip Rolls; T1 & T2 - Endless Tape Belts.**

It is difficult to specify the bath compositions, as the conditions are variable. The first bath may contain 0.5% soap and 0.1% sodium carbonate and the second bath only water. For three-bowl machine, the additional second bath may contain 0.25% soap only. The concentrations are maintained by intermediate additions. Non-ionic detergents (5g/l) can be used instead of soap. Final rinsing with water may be omitted, because the retained detergent will not hamper subsequent processes.

## **10.2. Brattice scouring machine**

It is used for scouring greater quantity of woollen yam. There may be two to five bowls. The yam is laid on a brattice or conveyor belt (B), made of stainless steel slats fitted one inch apart. The brattices are submerged under scouring liquor. The first brattice moves forward with the hanks and at the end of the brattice, the hanks fall on a second brattice, below the first one, which moves in the backward direction.

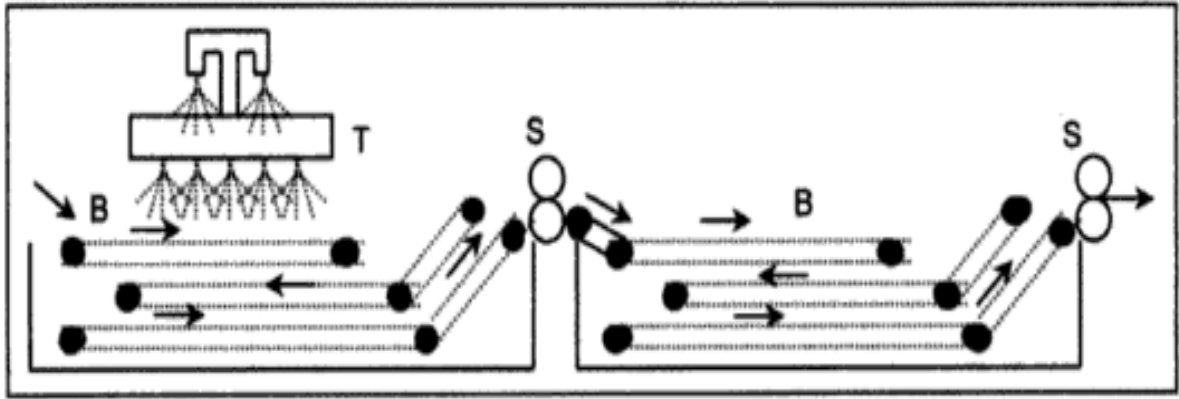

**Figure: Brattice Scouring Machine**

**B - Brattice or Conveyor Belt; S - Squeezing Rolls; T - Tray**

As the hanks reach the end of the second brattice, they fall on a third brattice moving forward. At the end of the third brattice, they pass through a pair of squeezing rollers (S) before entering next bowl. During the submerged passages along with the brattices, the hanks are held firmly in position between two adjacent brattices. The bowls work on counter current principle. The heavily soiled liquor is continuously discharged from the first bowl and a corresponding amount of clearer detergent solution is transferred from the subsequent bowl. In the first bowl, the liquor is continuously pumped and delivered to a tray (T) situated over the top brattice. The tray is perforated at the bottom through which the liquor is sprinkled on to the hanks of yam laid on the brattice.

The yams wound on packages like cheese, may be scoured and dyed in a package dyeing machine. Synthetic detergents are more preferable than soap, as these are more water-soluble and less liable for the formation of insoluble deposits. Complete rinsing in this machine is difficult, but residual detergents have no adverse effect on subsequent processes. The scouring may be done for 20-30 minutes at 50-55°C with 0.2% detergent solution.

## Chapter 11

### WOOL FABRIC SCOURING

Wool in fabric form can be scoured on Winch machine and soft flow dyeing machine.

#### 11.1. Wool Scouring on Winch

The scouring in rope form is mostly done in Dolly scouring machine resembling a winch dyeing machine. The machine consists of a pair of heavy squeeze rollers (R) and guide rollers (G). A trough (T) situated under the squeezing rollers to collect the liquor expressed by them. Two valves (W) are fitted into the trough so that the collected liquor can either be returned to the vessel (V), or be discharged. The discharge is necessary when the scouring process is nearing completion and the liquor is considerably soiled.

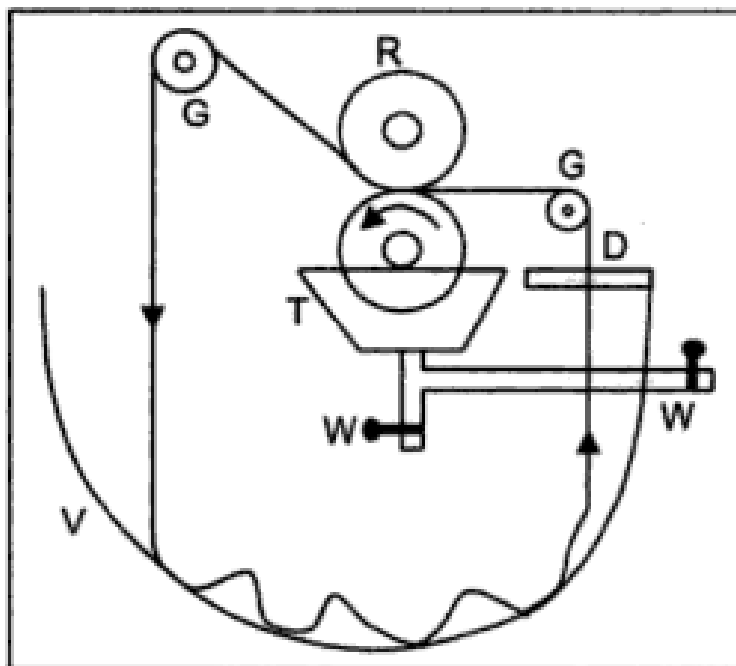

- D – Dividing Rods**
- G – Guide Roll**
- R – Roller (Squeeze)**
- T – Trough**
- V – Vessel**
- W – Valves**

**Figure: Dolly Scouring Machine**

The pieces of fabrics (about 60-70metres for worsted fabric) are made into an endless chain, which is threaded, in rope form, through the squeezing and guide rollers. Twelve or more ropes can be processed simultaneously keeping

the ropes side by side and separated by dividing rods (D). The M:L ratio may be as low as 2:1, which is much smaller as compared to that employed for scouring of cotton. For certain varieties, however, a higher ratio is maintained so that the fabric floats in the liquor, which opens it somewhat, and prevents watermarks.

Scouring liquor composition depends on the nature of the oils to be removed. Lubricants, prepared from hydrolysis of natural oils and fats, require sodium carbonate (about 3-4% on the weight of material) in the scouring bath at 35-40°C. Low quality woollen goods contain as much as 15 - 20% oil and require treatment with 4-5% of sodium carbonate. It may be necessary to repeat the operation with lesser alkali before final rinsing. Worsted goods generally contain very low amount of oil. About 0.5-1.0% (o.w.m.) of soap or synthetic detergent is usually adequate. To ensure alkalinity, sometimes 1% sodium carbonate or ammonia is added.

## 11.2. Wool Scouring on Jet/Overflow Dyeing Machine

Since 1971, there has been a rapid development in the field of jet and overflow machines. In jet dyeing of soft flow machines, both the goods and the dye liquor are moved. The cloth in rope form is lifted out of the dye liquor by a small reel and, together with the circulating dye liquor, is drawn through the jet or venturi and passes to the back of the machine. A venture (or nozzle) is a pipe that narrows and then widens out again. Scouring liquor is pumped through the venture, and it flows faster through the narrow part, causing suction that moves the cloth forward.

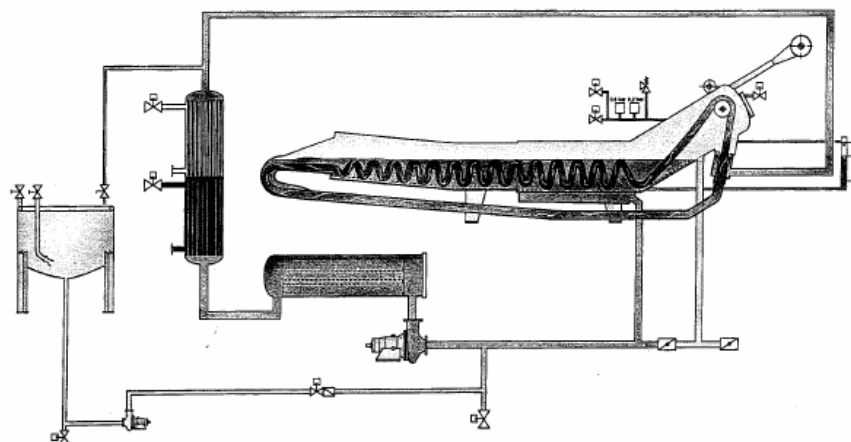



### ***Figure: Jet dyeing machine***

The speed at which the cloth moves around the machine is varied by adjusting the amount of liquor flow to the venture, and may be as high as 400 metres per minute. It was logical that jet dyeing machines should be considered for the dyeing of wool fabrics since replacements were needed for the old winches, and also a machine was required which would overcome the problems of winch dyeing, particularly the formation of running marks.

Then have recently modified the Then flow machine, specifically with wool fabrics in mind. The jet has been replaced with a specially designed overflow system, which guarantees an intensive liquor flow action on the fabric rope with the additional feature of optimum fabric displacement by means of generated impulses. The elongated storage section of the machine is almost fully flooded, so that the fabric rope is floated forwards through the liquor in a relaxed state towards the take-up point. This ensures a gentle fabric transport, rendering the machine specially suitable for dyeing goods with a delicate surface and a tendency to crease, such as woollen cloth.

## Chapter 12

### **SCOURING WASTE MANAGERMENTS**

Wool scouring produces a highly polluting effluent stream which is very difficult to degrade by biological microorganisms, especially the grease component. Other components of the effluent include pesticides, which are applied to wool to control various sheep parasites, and potassium, a nutrient which is contained in the suint. All pose significant problems in effluent treatment and disposal.

Dealing with the effluent provides one of the biggest challenges in a wool scouring business, which is often faced with increasingly stringent regulations. These demand an environmentally responsible performance in all aspects of wool scouring operations and sophisticated systems are now used to ensure that scouring wastes are dealt with efficiently and responsibly. The principles of waste minimisation involve

#### **12.1. Basics of Waste Minimisation**

1. Reducing the generation of waste through the recovery of wool grease (wool wax);
2. Reusing any waste where possible. While the waste cannot be used directly, the reuse of process liquors by passing them through contaminant recovery loops maximises the reuse of water and chemicals;
3. Reclaiming waste that cannot be reused. Ideally, all scouring wastes should be reclaimed;
4. Recycling as much unused reclaimed material as possible. If all the available water in the effluent was recycled, then there would be no liquid effluent discharges to the environment.

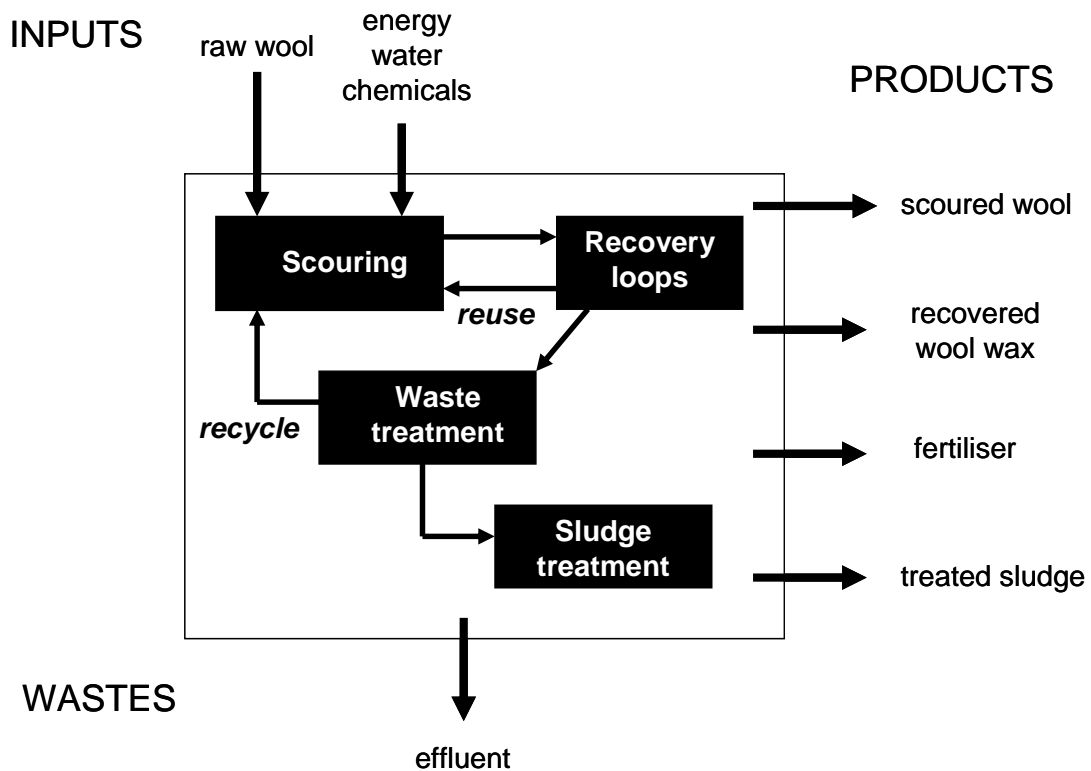

**Figure: Waste minimisation in wool scouring**

## 12.2. Primary Treatments

Basic (i.e. primary) treatment systems involve combining the various aqueous discharges and after centrifuging these are discharged from the plant with or without further treatment. Only a proportion of the wool grease and dirt (around 30%) is removed from the recovery loops that continuously treat the scouring liquors before returning them to the scour. The remaining contaminants are discharged from the scour as waste water.

Modern scouring effluent treatment systems:

1. Reduce the amount and variability of the discharge,
2. Remove settleable solids and fibre, and
3. Recover as much wool grease and heat as possible.

Figure below shows one such system as developed by WRONZ (Wool Research Organisation of New Zealand).

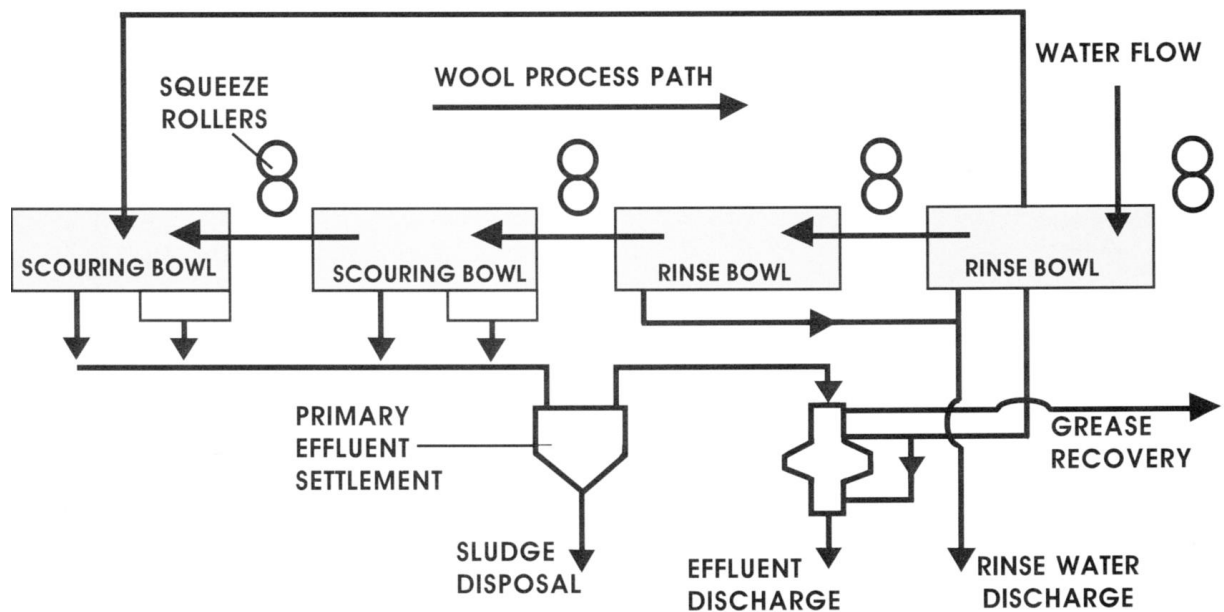

**Figure: WRONZ effluent treatment system**

A counter-flow system is used, with the liquor flowing from the first bowl passing through a primary dirt removal stage and then to a grease centrifuge. A proportion of the partially degreased water is returned to the first main scouring bowl. Different techniques are used to remove the various types of pollutants in the scour effluent:

- **Fibre removal** is carried out on hot liquors using screens, which must be cleaned at regular intervals to remove grease and grit.
- **Suspended solids removal** is carried out in a settling tank where the particles of dirt fall to the bottom of the tank to be removed as a sludge.
- **Grease removal** is the major pollutant and about 45 - 50% of grease can be removed by centrifuging.
- **Heat removal** by heat exchangers reduces the heat content of the primary effluent before it is discharged.

More complex (secondary and tertiary) treatment systems enable more wool grease to be removed from the effluent stream, and reduce the amount of water and solids discharged to the environment through the recovery of various components for use as fertilisers etc.

### 12.3. Other treatments

Wool scouring, as a wet process, also provides an opportunity for various chemical treatments that may be undertaken in the scouring or rinse bowls. For example:

- Hydrogen peroxide is often used as a bleach to further brighten good colour wools
- Sodium metabisulphite is sometimes used as a bleach to reduce the yellowness of average and poor colour wools
- Insect resistant (i.e. mothproofing) chemicals may be added
- Organic acids such as acetic or formic acid can be added to adjust the pH of the wool
- A bacteriostat may be added to sanitise wool destined for bedding products
- Various 'fibre differentiation' treatments that modify the lustre, dyeability and other wool characteristics are conveniently carried out as wet processes in a wool scour.

# Chapter 13

## **INSTRUCTIONS DURING SHIFT CHANGE OVER**

### **Taking charge of duties while starting of shift:**

- ❖ Come at least 10 - 15 minutes earlier to the work place.
- ❖ Meet the previous shift operator and discuss regarding the issues faced by them with respect to the quality or production or spare or safety or any other specific instruction etc.
- ❖ Understand the fabric being processed & process running on the machine.
- ❖ Ensure technical details are mentioned on the job card & display in machine.
- ❖ Check the next batch to be processed is ready near the machine.
- ❖ Check the cleanliness of the machines & other work areas.
- ❖ Question the previous shift operator for any deviation in the above and bring the same to the knowledge of the shift superior.

### **Handing over charge at the end of shift:**

- ❖ Properly hand over the shift to the incoming operator.
- ❖ Provide the details regarding fabric quality & the process running on the machine.
- ❖ Provide all relevant information regarding the stoppages or breakdown in the machine, any damage to the material or machine.
- ❖ Ensure the next lot to be processed is ready near the machine
- ❖ Get clearance from the incoming counterpart before leaving the work spot.
- ❖ Report to the shift supervisor in case the next shift operator doesn't report for the shift.
- ❖ Report to the shift supervisor about the quality / production / safety issues/ any other issue faced in the shift and leave the department only after getting concurrence for the same from supervisor.
- ❖ Collect the wastes from waste bags weigh them & transport to storage area.

## Chapter 14

### **IMPORTANCE OF HEALTH AND SAFETY**

- ❖ To minimize exposure to hazardous chemicals appropriate personal protective equipment, such as Hand Gloves, Safety Glasses, Gum Boots, Masks, Head cap, etc., should be used.
- ❖ Never handle chemicals with bare hands
- ❖ Training should be provided on handling of solvents and other harmful chemicals, and how to deal with accidental spills, contact with skin and eyes, and ingestion of chemicals.
- ❖ Report any service malfunctions in the machine that cannot be rectified to the supervisor.
- ❖ Store materials and equipment at their designated places.
- ❖ Minimize health and safety risks to self and others due to own actions.
- ❖ Monitor the workplace and work processes for potential risks.
- ❖ Do not carry any metallic parts during machine running as there are chances of fire and damage to machine parts.
- ❖ Take action based on instructions in the event of fire, emergencies or accidents, participate in mock drills/ evacuation procedures organized at the workplace as per organization procedures.
- ❖ Hazardous waste must be disposed of properly in accordance with manufacturer's guidelines (MSDS) and national policies.
- ❖ Exit passageways and stair cases must never be blocked with obstacles and all stairs should have hand rails.
- ❖ Employees should be given access to safe drinking water as well as a clean area for meals.
- ❖ Emergency exit doors should never be locked.

- ❖ Proper lighting and ventilation need to be ensured and machinery must be well maintained to avoid accidents.
- ❖ Sufficient fire extinguishers should be made available and signs should be placed in prominent places so that people are aware of their presence.
- ❖ There should also be signs saying “No Food and Drink’ in areas such as the laboratory, store room and factory floor, and any other areas where it is not safe to consume food.
- ❖ Hazardous chemicals should be clearly marked in an appropriate language and with clear symbols that people have to be trained to recognize and understand.
- ❖ Signs should be placed near inflammable substances stating that it is not permitted to smoke or have open fires.